

User Guide

Lenovo
ThinkStation

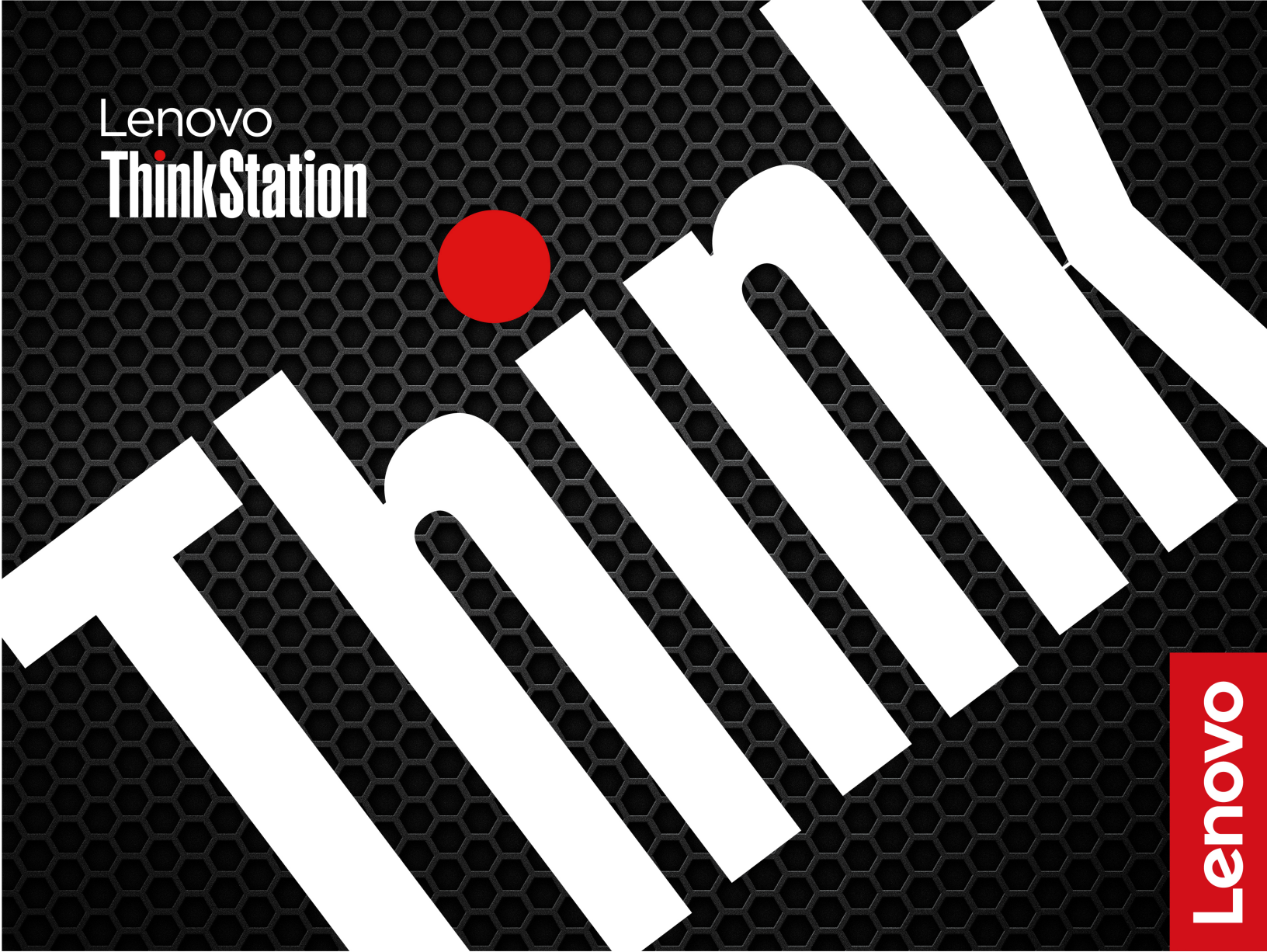

Lenovo

ThinkStation P620

Read this first

Before using this documentation and the product it supports, ensure that you read and understand the following:

- *Safety and Warranty Guide*
- [Generic Safety and Compliance Notices](#)
- *Setup Guide*

Tenth Edition (September 2025)

© Copyright Lenovo 2020, 2025.

LIMITED AND RESTRICTED RIGHTS NOTICE: If data or software is delivered pursuant to a General Services Administration "GSA" contract, use, reproduction, or disclosure is subject to restrictions set forth in Contract No. GS-35F-05925.

Contents

About this documentation iii

Chapter 1. Meet your computer 1

Front	1
Rear	3
System board illustration	4
Internal storage drives	7
Features and specifications	9
Statement on USB transfer rate	10
System memory speed	10
Operating environment	10

Chapter 2. Get started with your computer 12

Connect to networks	12
Connect to the wired Ethernet	12
Connect to Wi-Fi networks (for selected models)	12
The Vantage app	12
Use multimedia	12
Use audio	13
Connect an external display	13

Chapter 3. Explore your computer 14

Manage power	14
Set power button behaviors	14
Set the power plan	14
Transfer data	14
Connect to a Bluetooth-enabled device (for selected models)	14
Use the optical drive (for selected models)	15
Use a media card (for selected models)	15
Purchase accessories	15

Chapter 4. Secure your computer and information 17

Lock the computer	17
Use passwords	18
Use software security solutions.	19
Use Windows firewalls	19
Use Computrace Agent software embedded in firmware (for selected models)	20
Use BIOS security solutions	20
Erase all storage drive data	20
Use the cover presence switch	20
Use Smart USB Protection.	21

Chapter 5. UEFI BIOS 22

What is UEFI BIOS.	22
Enter the BIOS menu.	22
Navigate in the BIOS interface	22
Change the display language of UEFI BIOS	22
Change the display mode of UEFI BIOS	23
Set the system date and time	23
Change the startup sequence	23
Enable or disable the configuration change detection feature	24
Enable or disable the automatic power-on feature	24
Enable or disable the ErP LPS compliance mode	24
Change the fan speed level	25
CPU locking when PSB is enabled	25
Change BIOS settings before installing a new operating system	25
Update the UEFI BIOS	25
From the Vantage app	25
From the Lenovo Support Web site	26
From the Windows Update	26
Remote update via Windows Remote Desktop	26
UEFI BIOS self-healing recovery	26
Recover from a BIOS update failure	27
Clear CMOS	27

Chapter 6. RAID 28

What is RAID	28
Select RAID mode	28
RAID Levels	28
Configure RAID with RAIDXpert2 Configuration Utility	29

Chapter 7. Diagnostics 32

Lenovo diagnostic tools	32
Use the Vantage app.	32

Chapter 8. CRU replacement 34

What is CRU	34
Replace a CRU	35
ID badge.	35
Wi-Fi antenna	37
Computer cover	39
Device in the flex bay	43
Storage drive in the front-access storage enclosure	46
Device in the multi-drive conversion kit	49
Front panel I/O cage	54

Cover presence switch	55	Self-help resources	92
Storage drive in a storage drive bay	56	Call Lenovo	93
Storage drive cage	59	Before you contact Lenovo	93
M.2 solid-state drive	62	Lenovo Customer Support Center	94
U.2 or U.3 solid-state drive in an U.2 or U.3 solid-state drive PCIe adapter	72	Certification-related information	95
Power supply assembly	75	Compliance information	95
PCIe card	76	Purchase additional services.	95
Full-length PCIe card	80	Accessibility features.	95
Super capacitor module.	84	Appendix A. Supplemental information about the Ubuntu operating system 96	
Front fan assembly.	85	Appendix B. Notices and trademarks. 97	
Rear fan assembly	87		
Memory module active cooler and duct.	88		
Memory module.	89		
Chapter 9. Help and support 92			

About this documentation

- Illustrations in this documentation might look different from your product.
- Depending on the model, some optional accessories, features, and software programs might not be available on your computer.
- Depending on the version of operating systems and programs, some user interface instructions might not be applicable to your computer.
- Documentation content is subject to change without notice. Lenovo makes constant improvements on the documentation of your computer, including this *User Guide*. To get the latest documentation, go to: <https://pcsupport.lenovo.com>
- Microsoft® makes periodic feature changes to the Windows® operating system through Windows Update. As a result, some information in this documentation might become outdated. Refer to Microsoft resources for the latest information.

Chapter 1. Meet your computer

Front

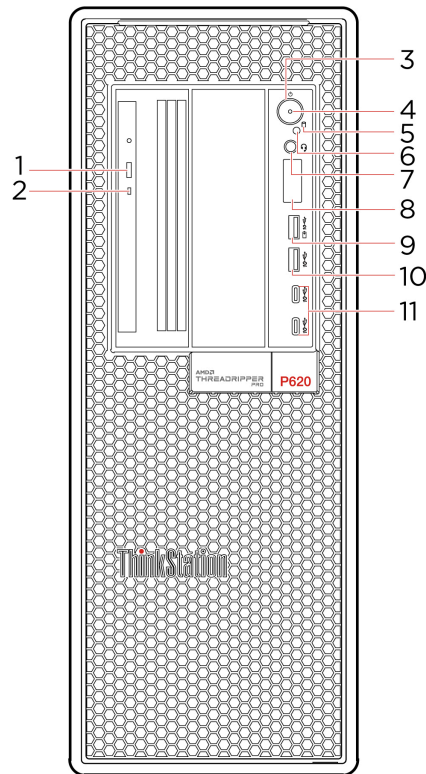

Item	Description
1. Optical drive eject button*	Eject the optical drive tray.
2. Optical drive activity indicator*	This indicator is on when the optical drive is in use.
3. Power button	<p>Press to turn on the computer.</p> <p>To turn off the computer, open the Start menu, click Power, and then select Shut down.</p> <p>The indicator in the power button shows the system status of your computer.</p> <ul style="list-style-type: none"> • On: The computer is starting up or working. • Off: The computer is off or in hibernation mode. • Blinking slowly: The computer is in sleep mode.
4. Power indicator	This indicator is on when the computer is turned on.
5. Storage drive activity indicator	This indicator is on when the storage drive is in use.
6. Photoelectric sensor*	This sensor receives the flash light sent by the Lenovo PC Diagnostics application installed in the smartphone. Then, the photoelectric sensor triggers the computer to send the tune of the detected error to the smartphone for users to decode the error.

Item	Description
7. Headset connector	Connect a headset or headphones to your computer.
8. Four-digit diagnostic display	Display a four-digit error code when an issue or error is detected. You can check the error code at https://www.thinkworkstationsoftware.com/?view=codes .
9. USB 3.2 connector Gen 2 (with charging function)	<ul style="list-style-type: none"> • Charge USB- compatible devices with the output voltage and current of 5 V and 2.1 A. • Enable you to experience higher data transfer rate when you connect USB-compatible devices, such as a USB keyboard, USB mouse, USB storage device, or USB printer.
10. USB 3.2 connector Gen 2	Enable you to experience higher data transfer rate when you connect USB-compatible devices, such as a USB keyboard, USB mouse, USB storage device, or USB printer.
11. USB-C® (3.2 Gen 2) connector	<ul style="list-style-type: none"> • Charge USB-C compatible devices with the output voltage and current of 5 V and 3 A. • Transfer data at USB 3.2 speed, up to 10 Gbps.

* for selected models

Rear

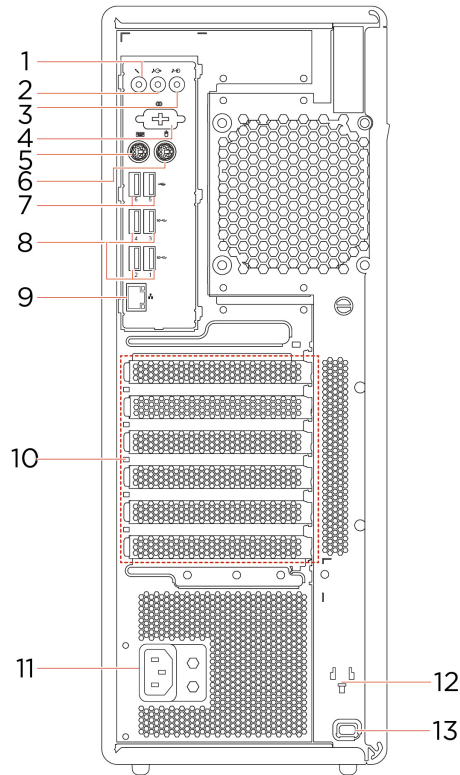

Item	Description
1. Microphone connector	Connect a microphone to your computer when you want to record sound or interact with the computer using speech recognition software.
2. Audio line-out connector	Send audio signals from the computer to external devices, such as powered stereo speakers, headphones, or multimedia keyboards. To connect a stereo system or other external recording device, connect a cable between the audio line-in connector of the device and the audio line-out connector of the computer. Note: If your computer has both an audio line-out connector and a headset or headphone connector, always use the headset or headphone connector for earphones, headphones, or a headset. The headphone connector does not support headset microphones.
3. Audio line-in connector	Receive audio signals from an external audio device, such as a stereo system. To connect an external audio device, connect a cable between the audio line-out connector of the device and the audio line-in connector of the computer.
4. Serial connector*	Connect an external modem, a serial printer, or other devices that use a serial connector.
5. PS/2 keyboard connector*	Connect a keyboard that uses a Personal System/2 (PS/2) keyboard connector.
6. PS/2 mouse connector*	Connect a mouse, a trackball, or other pointing devices that use a PS/2 mouse connector.
7. USB 2.0 connectors	Connect USB-compatible devices, such as a USB keyboard, USB mouse, USB storage device, or USB printer.

Item	Description
8. USB 3.2 connectors Gen 2	Enable you to experience higher data transfer rate when you connect USB-compatible devices, such as a USB keyboard, USB mouse, USB storage device, or USB printer.
9. Ethernet connector	Connect to a local area network (LAN). When the green indicator is on, the computer is connected to a LAN. When the yellow indicator blinks, data is being transmitted.
10. PCI-Express card area	Install PCI-Express cards into this area to improve the operating performance of the computer. Depending on the computer model, the connectors in this area vary.
11. Power cord connector	Connect the power cord to your computer for power supply.
12. Key-nest slots	Install the key holder that comes with the computer-cover-lock key to the key-nest slots.
13. Security-lock slot	Lock your computer to a desk, table, or other fixtures through a Kensington-style cable lock.

* for selected models

System board illustration

Note: The system board might look slightly different from the illustration.

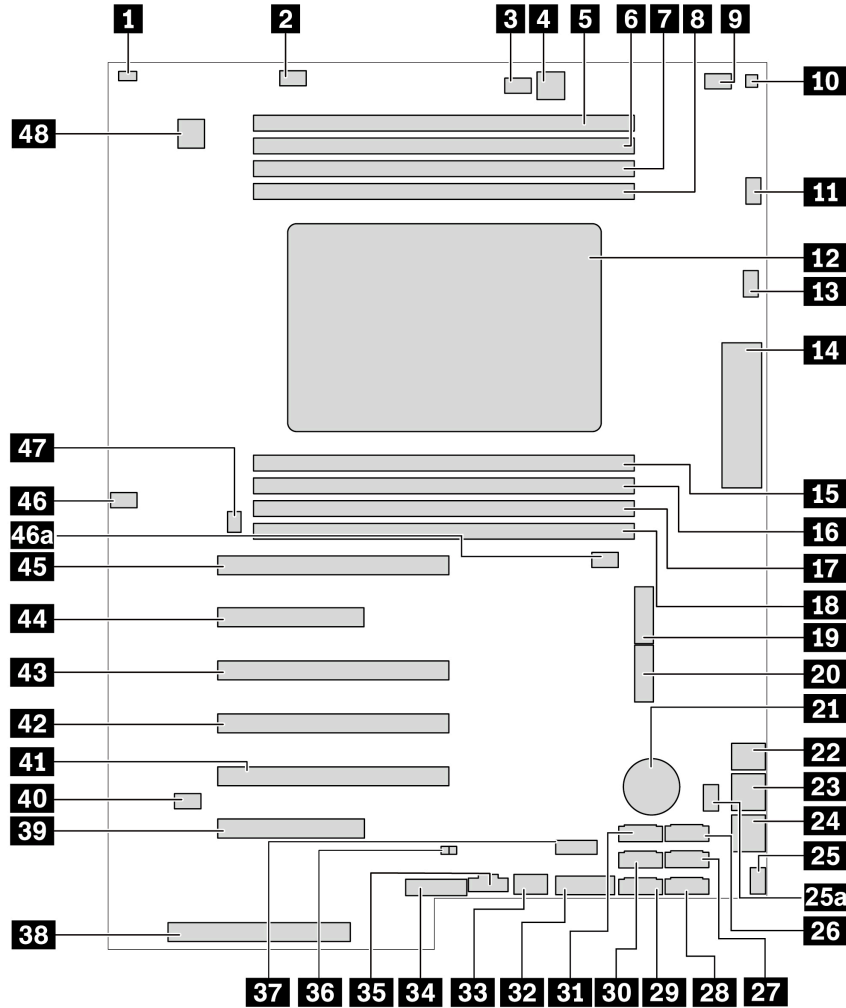

Figure 1. System board part locations

Item	Item
1 Cover presence switch connector (intrusion switch connector)	2 Memory fan connector 1
3 Optical-drive fan connector 2	4 4-pin power connector (for optical drive)
5 Memory slot 1	6 Memory slot 2
7 Memory slot 3	8 Memory slot 4
9 Optical-drive fan connector	10 Thermal-sensor connector
11 Microprocessor fan connector 1	12 Microprocessor
13 Microprocessor fan connector 2	14 Front input/output connector
15 Memory slot 5	16 Memory slot 6
17 Memory slot 7	18 Memory slot 8
19 M.2 solid-state drive slot 1	20 M.2 solid-state drive slot 2
21 Coin-cell battery	22 4-pin power connector (for storage drive)

Item	Item
23 8-pin power connector (for graphics card)	24 8-pin power connector (for graphics card)
25 / 25a Front-fan-assembly connector	26 eSATA / SATA 6 connector
27 SATA 4 connector	28 SATA 2 connector
29 SATA 1 connector	30 SATA 3 connector
31 SATA 5 connector	32 Media card reader (MCR) header
33 Internal USB 3.2 Gen 2 connector	34 Alternative Trusted Platform Module (TPM) header
35 Thunderbolt™ control connector	36 Internal-storage-drive activity indicator connector
37 Internal USB 2.0 connector	38 Power supply connector
39 PCIe 4.0 x8 card slot 6	40 Clear CMOS / Recovery jumper
41 PCIe 4.0 x16 card slot 5	42 PCIe 4.0 x16 card slot 4
43 PCIe 4.0 x16 card slot 3	44 PCIe 4.0 x8 card slot 2
45 PCIe 4.0 x 16 card slot 1	46 / 46a Memory fan connector 2
47 Rear-fan-assembly connector	48 Serial port (COM) connector

Internal storage drives

Internal storage drives are devices that your computer uses to read and store data. You can add drives to your computer to increase storage capacity and enable your computer to read other types of media.

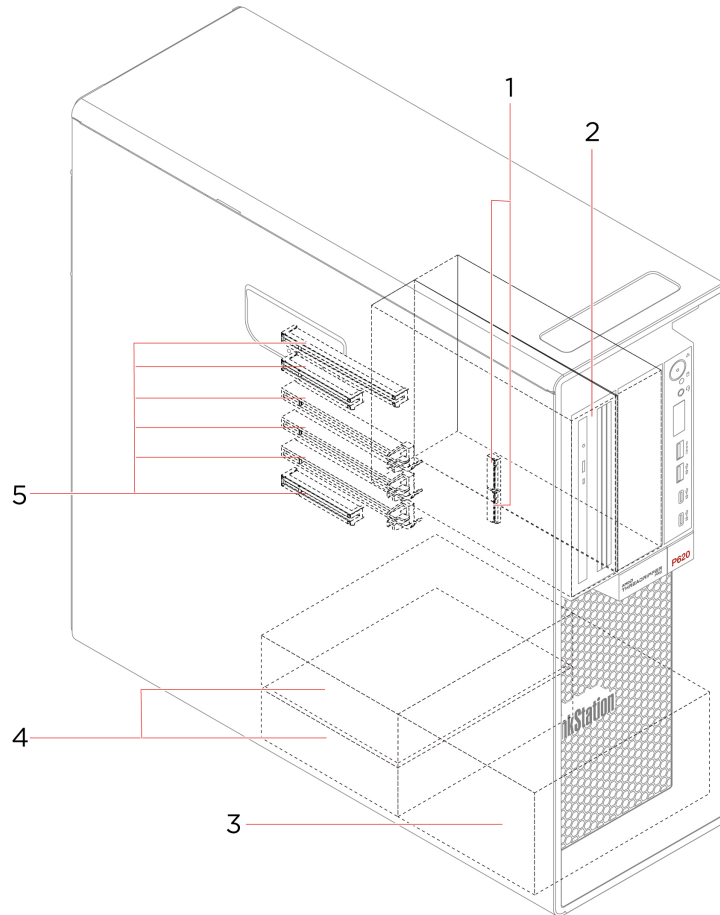

Item	Description
1. M.2 solid-state drive slots	One or two M.2 solid-state drives are installed in selected models.
2. Flex bay	<p>Depending on your computer model, the following devices might be installed in the flex bay:</p> <ul style="list-style-type: none"> • Flex module <ul style="list-style-type: none"> Depending on your computer model, the following parts might be installed in the flex module: <ul style="list-style-type: none"> – 15-in-1 card reader – Slim optical drive • Front-access storage enclosure • Multi-drive conversion kit <ul style="list-style-type: none"> Depending on your computer model, the following parts might be installed in the multi-drive conversion kit: <ul style="list-style-type: none"> – Internal storage drive – Slim optical drive • Slim-optical-drive adapter
3. Storage drive bays*	<p>You can install hard disk drives in the storage drive bays.</p> <p>Note: If you want to install storage drives into the optional-storage-drive bays, contact the Lenovo Customer Support Center for help.</p>
4. Storage drive bays	You can install hard disk drives in the storage drive bays.
5. PCIe slots	You can install compatible PCIe cards and PCIe solid-state drives in the PCIe card slots.

* for selected models

Features and specifications

Item	Description
Dimensions	<ul style="list-style-type: none">• Width: 165 mm (6.5 inches)• Height: 446 mm (17.6 inches)• Depth: 455 mm (17.9 inches)
Weight (without the packaging)	Maximum configuration as shipped: 24 kg (52.91 lb)
Hardware configuration	Type Device Manager in the Windows search box and then press Enter. Type the administrator password or provide confirmation, if prompted.
Power supply	1000-watt automatic voltage-sensing power supply
Electrical input	<ul style="list-style-type: none">• Input voltage: From 100 V ac to 240 V ac• Input frequency: 50/60 Hz
Microprocessor	To view the microprocessor information of your computer, right-click the Start button and then click System .
Memory	Up to eight double data rate 4 (DDR4) error correction code (ECC) registered dual inline memory modules (RDIMMs)
Storage device	<ul style="list-style-type: none">• Hard disk drive• M.2 solid-state drive*• U.2 or U.3 solid-state drive*• Slim optical drive*• 15-in-1 media card* <p>To view the storage drive capacity of your computer, type Disk Management in the Windows search box and then press Enter.</p> <p>Note: The storage drive capacity indicated by the system is less than the nominal capacity.</p>
Video features	<ul style="list-style-type: none">• PCIe x16 card slots on the system board for a discrete graphics card• Video connectors on a discrete graphics card:<ul style="list-style-type: none">– DVI connector– DisplayPort connector– Mini DisplayPort connector
Audio features	<p>The integrated audio card supports the following:</p> <ul style="list-style-type: none">• Audio line-in connector• Audio line-out connector• Headset connector• Internal speaker• Microphone connector

Item	Description
Expansion	<ul style="list-style-type: none"> • Flex bay • Storage drive bays • M.2 solid-state drive slots • Memory slots • PCI Express slots
Network features	<ul style="list-style-type: none"> • Bluetooth* • Ethernet LAN • Wireless LAN*

* for selected models

Statement on USB transfer rate

Depending on many factors such as the processing capability of the host and peripheral devices, file attributes, and other factors related to system configuration and operating environments, the actual transfer rate using the various USB connectors on this device will vary and will be slower than the data rate listed below for each corresponding device.

USB device	Data rate (Gbit/s)
3.2 Gen 1	5
3.2 Gen 2	10
3.2 Gen 2 × 2	20
Thunderbolt 3	40
Thunderbolt 4	40

System memory speed

The AMD Threadripper Pro microprocessor families compatible with this ThinkStation computer feature an integrated memory controller, which provides the microprocessor with direct access to the system memory. Because of this design, the system memory speed will be determined by a number of factors, including the microprocessor model and the type, speed, size (capacity), and number of DIMMs installed.

Notes:

- The actual system memory speed of the memory modules varies depending on the microprocessor model. For example, your computer comes with 2666 MT/s memory modules, but microprocessor only supports up to 2400 MT/s memory modules. Then the system memory speed will be no faster than 2400 MT/s.
- The microprocessor models supported in your computer might vary. For a list of supported microprocessor models, contact the Lenovo Customer Support Center.

Operating environment

Maximum altitude (without pressurization)

- Operating: From 0 m (0 ft) to 3048 m (10 000 ft)
- Storage: From 0 m (0 ft) to 12192 m (40 000 ft)

Temperature

- Operating: From 10°C (50°F) to 35°C (95°F)
- Storage: From -40°C (-40°F) to 60°C (140°F)

Relative humidity

- Operating: 20%-80% (non-condensing)
- Storage: 10%–90% (non-condensing)

Chapter 2. Get started with your computer

Connect to networks

Your computer helps you connect to the world through a wired or wireless network.

Connect to the wired Ethernet

Connect your computer to a local network through the Ethernet connector on your computer with an Ethernet cable.

Note: For models with an Intel X710-T2L Ethernet adapter, it's recommended to prepare a Shielded Twisted Pair (STP) Category 6A Ethernet cable for Ethernet connection on the adapter.

Connect to Wi-Fi networks (for selected models)

If your computer includes a wireless LAN module, you can connect your computer to Wi-Fi® networks. The wireless LAN module on your computer may support different standards. For some countries or regions, use of 802.11ax may be disabled according to local regulations.

1. Click the network icon in the Windows notification area. A list of available wireless networks is displayed.
2. Select a network available for connection. Provide required information, if needed.

The Vantage app

The preinstalled Vantage app is a customized one-stop solution to help you maintain your computer with automated updates and fixes, configure hardware settings, and get personalized support.

To access the Vantage app, type *Vantage* in the Windows search box.

Key features

The Vantage app enables you to:

- Know the device status easily and customize device settings.
- Download and install UEFI BIOS, firmware and driver updates to keep your computer up-to-date.
- Monitor your computer health, and secure your computer against outside threats.
- Scan your computer hardware and diagnose hardware problems.
- Look up *warranty* status (online).
- Access *User Guide* and helpful articles.

Notes:

- The available features vary depending on the computer model.
- The Vantage app makes periodic updates of the features to keep improving your experience with your computer. The description of features might be different from that on your actual user interface.

Use multimedia

Use your computer for business or entertainment with the devices (such as a camera, a monitor, or speakers).

Use audio

To enhance the audio experience, connect speakers, headphones, or a headset to the audio connector.

Adjust the volume

1. Click the volume icon in the Windows notification area on the taskbar.
2. Follow the on-screen instructions to adjust the volume. Click the speaker icon to mute the audio.

Change the sound settings

1. Type Control Panel in the Windows search box and then press Enter. View by category.
2. Click **Hardware and Sound** → **Sound**.
3. Change the settings as you prefer.

Connect an external display

Connect a projector or a monitor to your computer to give presentations or expand your workspace.

Connect a wireless display

Ensure that both your computer and the wireless display support Miracast®.

Press Windows logo key + K and then select a wireless display to connect.

Change display settings

1. Right-click a blank area on the desktop and select display settings.
2. Select the display that you want to configure and change display settings of your preference.

Chapter 3. Explore your computer

Manage power

Use the information in this section to achieve the best balance between performance and power efficiency.

Set power button behaviors

You can define what the power button does according to your preference. For example, by pressing the power button, you can turn off the computer or put the computer to sleep or hibernation mode.

To change what the power button does:

1. Right-click the battery status icon and select **Power Options → Change what the power buttons do**.
2. Change the settings as you prefer.

Set the power plan

For ENERGY STAR® compliant computers, the following power plan takes effect when your computers have been idle for a specified duration:

Default power plan (when plugged into ac power)

- Turn off the display: After 10 minutes
- Put the computer to sleep: After 25 minutes

To awaken the computer from Sleep mode, press any key on your keyboard.

To reset the power plan:

1. Type Power Plan in the Windows search box and then press Enter.
2. Choose or customize a power plan of your preference.

Transfer data

Quickly share your files using the built-in Bluetooth technology among devices with the same features. You also can install a disc or media card to transfer data.

Connect to a Bluetooth-enabled device (for selected models)

You can connect all types of Bluetooth-enabled devices to your computer, such as a keyboard, a mouse, a smartphone, or speakers. Place the device that you are attempting to connect to less than 10 meters (33 feet) from the computer.

1. Type Bluetooth in the Windows search box and then press Enter.
2. Turn on Bluetooth, if it is off.
3. Select a Bluetooth device, and then follow the on-screen instructions.

Your Bluetooth device and computer will automatically connect the next time if the two devices are in range of each other with Bluetooth turned on. You can use Bluetooth for data transfer or remote control and communication.

Use the optical drive (for selected models)

If your computer has an optical drive, read the following information.

Know the type of your optical drive

1. Type Device Manager in the Windows search box and then press Enter. Type the administrator password or provide confirmation, if prompted.
2. Select an optical drive, and then follow the on-screen instructions.

Install or remove a disc

1. With the computer on, press the eject/close button on the optical drive. The tray slides out of the drive.
2. Insert a disc into the tray or remove a disc from the tray, and then press the eject/close button again to close the tray.

Note: If the tray does not slide out of the drive when you press the eject/close button, turn off the computer. Then, insert a straightened paper clip into the emergency-eject hole adjacent to the eject/close button. Use the emergency eject only in an emergency.

Record a disc

1. Insert a recordable disc into the optical drive that supports recording.
2. Do one of the following:
 - Type AutoPlay in the Windows search box and then press Enter. Turn on **Use AutoPlay for all media and devices**.
 - Open Windows Media Player.
 - Double-click the ISO file.
3. Follow the on-screen instructions.

Use a media card (for selected models)

If your computer has a SD-card slot, read the following information.

Install a media card

1. Locate the SD-card slot.
2. Ensure that the metal contacts on the card are facing the ones in the SD-card slot. Insert the card firmly into the SD-card slot until it is secured in place.

Remove a media card

Attention: Before removing the card:

1. Click the triangular icon in the Windows notification area to show hidden icons. Right-click the icon prompting you to safely remove hardware and eject media.
2. Select the corresponding item to eject the card from the Windows operating system.
3. Press the card and remove it from your computer. Store the card safely for future use.

Purchase accessories

Lenovo has a number of hardware accessories and upgrades to help expand the capabilities of your computer. Options include memory modules, storage devices, network cards, power adapters, keyboards, mice, and more.

To shop at Lenovo, go to <https://www.lenovo.com/accessories>.

Chapter 4. Secure your computer and information

Lock the computer

Note: You are responsible for evaluating, selecting, and implementing the locking device and security feature. Lenovo makes no comments, judgments, or warranties about the function, quality, or performance of the locking device and security feature. You can purchase computer locks from Lenovo.

Key lock

Locking the computer cover through a key lock prevents unauthorized access to the inside of your computer. The keys for the key lock are attached to the rear of the machine. For security, store the keys in a secure place when you are not using them.

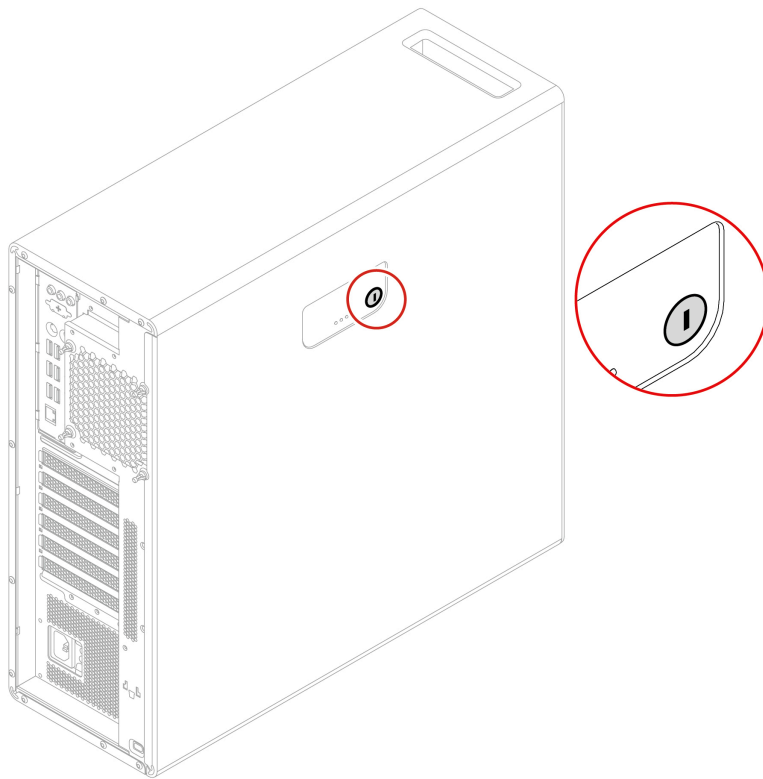

Kensington-style cable lock

Lock your computer to a desk, table, or other fixtures through a Kensington-style cable lock.

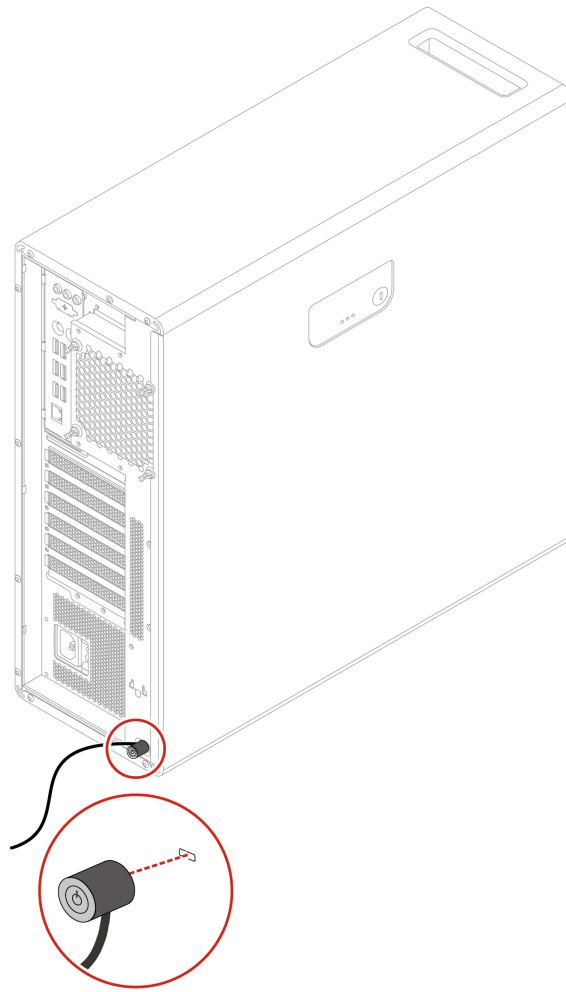

Use passwords

Password types

You can set the following passwords in UEFI (Unified Extensible Firmware Interface) BIOS (Basic Input/Output System) to prevent unauthorized access to your computer. However, you are not prompted to enter any UEFI BIOS password when your computer resumes from sleep mode.

- Power-on password

When a power-on password is set, you are prompted to enter a valid password each time the computer is turned on. The computer cannot be used until the valid password is entered.

- Supervisor password

Setting a supervisor password deters unauthorized users from changing configuration settings. If you are responsible for maintaining the configuration settings of several computers, you might want to set a supervisor password.

When a supervisor password is set, you are prompted to enter a valid password each time you try to enter the BIOS menu.

If both the power-on password and supervisor password are set, you can enter either password. However, you must use your supervisor password to change any configuration settings.

- Hard disk password

Setting a hard disk password prevents unauthorized access to the data on the storage drive. When a hard disk password is set, you are prompted to enter a valid password each time you try to access the storage drive.

Note: After you set a hard disk password, your data on the storage drive is protected even if the storage drive is removed from one computer and installed in another.

- System management password (for selected models)

You can enable the system management password to have the same authority as the supervisor password to control security related features. To customize the authority of the system management password through the UEFI BIOS menu:

1. Restart the computer. When the logo screen is displayed, press F1 or Fn+F1.
2. Select **Security** → **System Management Password Access Control**.
3. Follow the on-screen instructions.

If you have set both the supervisor password and the system management password, the supervisor password overrides the system management password.

Set, change, and remove a password

Before you start, print these instructions.

1. Restart the computer. When the logo screen is displayed, press F1 or Fn+F1.
2. Select **Security**.
3. Depending on the password type, select **Set Supervisor Password**, **Set Power-On Password**, **Set System Management Password**, or **Hard Disk Password** and press Enter.
4. Follow the on-screen instructions to set, change, or remove a password.
5. Press F10 or Fn+F10 to save the changes and exit.

You should record your passwords and store them in a safe place. If you forget the passwords, contact a Lenovo-authorized service provider.

Note: If the hard disk password is forgotten, Lenovo cannot remove the password or recover data from the storage drive.

Use software security solutions

This section provides software solutions to secure your computer and information.

Use Windows firewalls

A firewall can be hardware, software, or a combination of both depending on the level of security required. Firewalls work on a set of rules to determine which inbound and outbound connections are authorized. If the computer is preinstalled with a firewall program, it helps protect against computer Internet security threats, unauthorized access, intrusions, and Internet attacks. It also protects your privacy. For more information about how to use the firewall program, refer to the help system of your firewall program.

To use Windows firewalls:

1. Type **Control Panel** in the Windows search box and then press Enter. View by large icons or small icons.
2. Click **Windows Defender Firewall**, and then follow the on-screen instructions.

Use Computrace Agent software embedded in firmware (for selected models)

The Computrace Agent software is an IT asset management and computer theft recovery solution. The software detects if changes have been made on the computer, such as hardware, software, or the computer call-in location. You might have to purchase a subscription to activate the Computrace Agent software.

Use BIOS security solutions

This section provides BIOS solutions to secure your computer and information.

Erase all storage drive data

It is recommended that you erase all storage drive data before recycling a storage drive or the computer.

To erase all storage drive data:

1. Set a hard disk password for the storage drive you will recycle. See “Use passwords” on page 18.
2. Restart the computer. When the logo screen is displayed, press F1 or Fn+F1.
3. Select **Security** → **Hard Disk Password** → **Security Erase HDD Data** and press Enter.
4. Select the storage drive you will recycle and press Enter.
5. A message is displayed, prompting you to confirm the operation. Select **Yes** and press Enter. The erasing process begins.

Note: During the erasing process, the power button and the keyboard are disabled.

6. After the erasing process is completed, a message is displayed, prompting you to reset the system. Select **Continue**.

Note: Depending on the storage drive capacity, the erasing process will take half an hour to three hours.

7. After the resetting process is completed, one of the following will happen:
 - If the data on the system storage drive is erased, you will be prompted that no operating system is available.
 - If the data on the non-system storage drive is erased, the computer restarts automatically.

Use the cover presence switch

The cover presence switch prevents the computer from logging in to the operating system when the computer cover is not properly installed or closed.

To enable or disable the cover presence switch on the system board:

1. Restart the computer. When the logo screen is displayed, press F1 or Fn+F1.
2. Select **Security** → **Cover Tamper Detected** and press Enter.
3. Select **Enabled** or **Disabled** and press Enter.
4. Press F10 or Fn+F10 to save the changes and exit.

If the cover presence switch is enabled and the computer cover is not correctly installed or closed, an error message will be displayed when you turn on the computer. To bypass the error message and log in to the operating system:

1. Properly install or close the computer cover.
2. Enter the BIOS menu, save and then exit.

Use Smart USB Protection

The Smart USB Protection function is a security function that helps prevent data from being copied from the computer to USB storage devices connected to the computer. You can set the Smart USB Protection function to one of the following modes:

- **Disabled** (default setting): You can use the USB storage devices without limitation.
- **Read Only**: You cannot copy data from the computer to the USB storage devices. However, you can access or modify data on the USB storage devices.
- **No Access**: You cannot access the USB storage devices from the computer.

To configure the Smart USB Protection function:

1. Restart the computer. When the logo screen is displayed, press F1 or Fn+F1.
2. Select **Security** → **Smart USB Protection** and press Enter.
3. Select the desired setting and press Enter.
4. Press F10 or Fn+F10 to save the changes and exit.

Chapter 5. UEFI BIOS

This chapter provides information about configuring and updating UEFI BIOS, and clearing CMOS.

What is UEFI BIOS

Note: The operating system settings might override any similar settings in UEFI BIOS.

UEFI BIOS is the first program that the computer runs when the computer is turned on. UEFI BIOS initializes the hardware components and loads the operating system and other programs. Your computer comes with a setup program with which you can change UEFI BIOS settings.

Enter the BIOS menu

Restart the computer. When the logo screen is displayed, press F1 or Fn+F1 to enter the BIOS menu.

Note: If you have set BIOS passwords, enter the correct passwords when prompted. You also can select **No** or press Esc to skip the password prompt and enter the BIOS menu. However, you cannot change the system configurations that are protected by passwords.

Navigate in the BIOS interface

Attention: The default configurations are already optimized for you in **boldface**. Improper change of the configurations might cause unexpected results.

Depending on your keyboard, you can navigate in the BIOS interface by pressing the following keys, or combinations of Fn and the following keys:

Keys	Description
F1 or Fn+F1	Display the General Help screen.
Esc or Fn+Esc	Exit the submenu and return to the parent menu.
↑ ↓ or Fn+↑ ↓	Locate an item.
← → or Fn+← →	Select a tab.
+/- or Fn++/-	Change to a higher or lower value.
Enter	Enter the selected tab or submenu.
F9 or Fn+F9	Restore to the default settings.
F10 or Fn+F10	Save your configuration and exit.

Change the display language of UEFI BIOS

UEFI BIOS supports three or four display languages: English, French, simplified Chinese, and Russian (for selected models).

To change the display language of UEFI BIOS:

1. Select **Main → Language** and press Enter.
2. Set the display language as desired.

Change the display mode of UEFI BIOS

You can use UEFI BIOS in the graphic mode or the text mode according to your needs.

To change the display mode of UEFI BIOS:

1. Restart the computer. When the logo screen is displayed, press F1 or Fn+F1.
2. Select **Main → Setup Mode Select** and press Enter.
3. Set the display mode as desired.

Set the system date and time

1. Restart the computer. When the logo screen is displayed, press F1 or Fn+F1.
2. Select **Main → System Time & Date** and press Enter.
3. Set the system date and time as desired.
4. Press F10 or Fn+F10 to save the changes and exit.

Change the startup sequence

If the computer does not start up from a device as expected, you can change the startup device sequence permanently or select a temporary startup device.

Change the startup device sequence permanently

1. Depending on the type of the storage device, do one of the following:
 - If the storage device is internal, go to step 2.
 - If the storage device is a disc, ensure that the computer is on or turn on the computer. Then, insert the disc into the optical drive.
 - If the storage device is an external device other than a disc, connect the storage device to the computer.
2. Restart the computer. When the logo screen is displayed, press F1 or Fn+F1.
3. Select **Startup**, and then follow the on-screen instructions to change the startup sequence.
4. Press F10 or Fn+F10 to save the changes and exit.

Select a temporary startup device

Note: Not all discs and storage drives are bootable.

1. Depending on the type of the storage device, do one of the following:
 - If the storage device is internal, go to step 2.
 - If the storage device is a disc, ensure that the computer is on or turn on the computer. Then, insert the disc into the optical drive.
 - If the storage device is an external device other than a disc, connect the storage device to the computer.
2. Restart the computer. When the logo screen is displayed, press F12 or Fn+F12.
3. Select the storage device as desired and press Enter.

If you want to change the startup device sequence permanently, select **Enter Setup** on Startup Device Menu and press Enter to enter the BIOS menu.

Enable or disable the configuration change detection feature

If you enable configuration change detection, when the POST detects configuration changes of some hardware devices (such as storage drives or memory modules), an error message will be displayed when you turn on the computer.

To enable or disable the configuration change detection feature:

1. Restart the computer. When the logo screen is displayed, press F1 or Fn+F1.
2. Select **Security** → **Configuration Change Detection** and press Enter.
3. Enable or disable the feature as desired.
4. Press F10 or Fn+F10 to save the changes and exit.

To bypass the error message and log in to the operating system, press F2 or Fn+F2. To clear the error message, enter the BIOS menu, save and then exit.

Enable or disable the automatic power-on feature

The Automatic Power On item in UEFI BIOS provides various options for you to make your computer start up automatically.

To enable or disable the automatic power-on feature:

1. Restart the computer. When the logo screen is displayed, press F1 or Fn+F1.
2. Select **Power** → **Automatic Power On** and press Enter.
3. Select the feature as desired and press Enter.
4. Enable or disable the feature as desired.
5. Press F10 or Fn+F10 to save the changes and exit.

Enable or disable the ErP LPS compliance mode

Lenovo computers meet the eco-design requirements of the ErP Lot 3 regulation. For more information, go to:

<https://www.lenovo.com/us/en/compliance/eco-declaration>

You can enable the ErP LPS compliance mode to reduce the consumption of electricity when the computer is off or in sleep mode. When the ErP LPS compliance mode is enabled, you can wake up the computer by pressing the power button.

To enable or disable the ErP LPS compliance mode:

1. Restart the computer. When the logo screen is displayed, press F1 or Fn+F1.
2. Select **Power** → **Enhanced Power Saving Mode** and press Enter.
3. Depending on whether you select **Enabled** or **Disabled**, do one of the following:
 - If you select **Enabled**, press Enter. Then, select **Power** → **Automatic Power On** and press Enter. Check whether the Wake on LAN feature is disabled automatically. If no, disable it.
 - If you select **Disabled**, press Enter. Then, go to the next step.
4. Press F10 or Fn+F10 to save the changes and exit.

To meet the off mode requirement of ErP compliance, you need to disable the Fast Startup function.

1. Go to **Control Panel** and view by large icons or small icons.

2. Click **Power Options** → **Choose what the power buttons do** → **Change settings that are currently unavailable**.
3. Clear the **Turn on fast startup (recommended)** option from the **Shutdown settings** list.

Change the fan speed level

You can change the fan speed level, from level 1 to level 7, to adjust the thermal performance of your computer. A higher fan speed level indicates better thermal performance with more noise.

To change the fan speed level:

1. Restart the computer. When the logo screen is displayed, press F1 or Fn+F1.
2. Select **Power** → **Fan Control Stepping** and press Enter.
3. Set the fan speed level as desired.
4. Press F10 or Fn+F10 to save the changes and exit.

CPU locking when PSB is enabled

Platform Secure Boot is an AMD technology to enhance platform security. With this feature enabled in the UEFI BIOS, after you replace the failing CPU with a new one and start the system, you will be prompted that the new CPU will be locked and only work with the current computer model. You can select the option of your preference.

Change BIOS settings before installing a new operating system

BIOS settings vary by operating system. Change the BIOS settings before installing a new operating system.

Microsoft constantly makes updates to the Windows operating system. Before installing a particular Windows version, check the compatibility list for the Windows version. For details, go to:

<https://support.lenovo.com/us/en/solutions/windows-support>

To change the BIOS settings:

1. Restart the computer. When the logo screen is displayed, press F1 or Fn+F1.
2. From the main interface, select **Security** → **Secure Boot** and press Enter.
3. Depending on the operating system to be installed, do one of the following:
 - To install a Windows operating system that supports secure boot, select **Enabled** for **Secure Boot**.
 - To install an operating system that does not support secure boot, such as some Linux operating systems, select **Disabled** for **Secure Boot**.
4. Press F10 or Fn+F10 to save the changes and exit.

Update the UEFI BIOS

When you install a new program, device driver, or hardware component, you might need to update the UEFI BIOS.

Download and install the latest UEFI BIOS update package by one of the following methods:

From the Vantage app

Follow the instructions to update the UEFI BIOS from the Vantage app.

- Step 1. Open the Vantage app, and then click **Device → System Update**.
- Step 2. If the latest UEFI BIOS update package is available, follow the on-screen instructions to download and install the package.

From the Lenovo Support Web site

Follow the instructions to update the UEFI BIOS from the Lenovo Support Web site.

- Step 1. Go to <https://pcsupport.lenovo.com> and select the entry for your computer.
- Step 2. Click **Drivers & Software → Manual Update → BIOS/UEFI**.
- Step 3. Follow the on-screen instructions to download and install the latest UEFI BIOS update package.

From the Windows Update

Follow the instructions to update the UEFI BIOS from the Windows Update.

- Step 1. Type **Settings** in the Windows search box and press Enter.
- Step 2. Click **Windows Update → Check for Updates**.
- Step 3. If a BIOS update package appears in your update list, click **Download or Install** to initiate the update.

Remote update via Windows Remote Desktop

Prerequisite: Before proceeding, ensure the target computer has a display connected. If not, attach one to perform a local UEFI BIOS update using the latest version from Lenovo Support Web site. Once completed, subsequent UEFI BIOS updates can be performed remotely without a display.

- Step 1. Establish a Remote Desktop Protocol (RDP) connection to the target computer.
- Step 2. Through the RDP interface, remotely update the UEFI BIOS using one of these methods.
 - “From the Vantage app” on page 25
 - “From the Lenovo Support Web site” on page 26
 - “From the Windows Update” on page 26
- Step 3. After installation, the system will automatically reboot multiple times (around 20 minutes). The remote connection will terminate during reboots — reconnect after the final reboot to verify successful update.

UEFI BIOS self-healing recovery

When you update the UEFI BIOS, you might encounter a power failure or other critical operations that cause the boot to crash. In this case, the UEFI BIOS self-healing recovery function is launched automatically to help UEFI BIOS recover to boot, and help you save settings as much as possible. User input will be blocked and no user operation is needed during the self-healing recovery process. Do not turn off your computer. System will enter setup and display the progress when the primary image is recovered.

During the self-healing recovery process, the four-digit diagnostic display will indicate that self-healing recovery is in progress and show the percentage of the progress alternatively. The whole process might take you about 15 minutes.

If the self-healing recovery fails, the system will hang. You can contact a Lenovo-authorized service provider to have the computer serviced.

Recover from a BIOS update failure

1. Remove all media from the drives and turn off all connected devices.
2. Insert the BIOS update disc into the optical drive, and then turn off the computer.
3. Disconnect all power cords from electrical outlets. Then, remove any parts that impede access to the Clear CMOS jumper.
4. Move the jumper from the standard position to the Clear CMOS position.
5. Reconnect the power cords for the computer and the monitor to electrical outlets.
6. Turn on the computer and the monitor. When the computer beeps, the recovery process begins.
7. After the recovery process is completed, the computer will be turned off automatically.

Note: Depending on the computer model, the recovery process will take two to three minutes.

8. Disconnect all power cords from electrical outlets.
9. Move the jumper back to the standard position.
10. Reinstall all the parts that have been removed. Then, reconnect the power cords for the computer and the monitor to electrical outlets.
11. Turn on the computer and the monitor. When the logo screen is displayed, press F1 or Fn+F1.
12. To prevent data loss, ensure that BIOS settings are restored to an earlier point.

Clear CMOS

1. Remove all media from the drives and turn off all connected devices and the computer.
2. Disconnect all power cords from electrical outlets. Then, remove any parts that impede access to the Clear CMOS jumper.
3. Move the jumper from the standard position to the Clear CMOS position.
4. Reconnect the power cords for the computer and the monitor to electrical outlets.
5. Turn on the computer and the monitor. When the computer beeps, wait for approximately 10 seconds.
6. Turn off the computer by holding the power button for approximately four seconds.
7. Disconnect all power cords from electrical outlets.
8. Move the jumper back to the standard position.
9. Reinstall all the parts that have been removed. Then, reconnect the power cords for the computer and the monitor to electrical outlets.
10. Turn on the computer and the monitor. When the logo screen is displayed, press F1 or Fn+F1.
11. To prevent data loss, ensure that BIOS settings are restored to an earlier point.

Chapter 6. RAID

What is RAID

Redundant Array of Independent Disks (RAID) is a technology that provides increased storage functions and reliability through redundancy. It also can improve data storage reliability and fault tolerance compared with single-drive storage systems. Data loss resulting from a drive failure can be prevented by reconstructing missing data from the remaining drives.

When a group of independent physical storage drives is set up to use RAID technology, they are in a RAID array. This array distributes data across multiple storage drives, but the array appears to the host computer as one single storage unit. Creating and using RAID arrays provides high performance, such as the expedited I/O performance, because several drives can be accessed simultaneously.

Select RAID mode

You can select the SATA RAID mode or NVMe RAID mode to configure RAID with RAIDXpert2 Configuration Utility.

1. Do one of the following to select the SATA RAID mode or NVMe RAID mode:
 - SATA RAID mode:
 - a. Restart the computer. When the logo screen is displayed, press F1 or Fn+F1.
 - b. Select **Devices** → **ATA Drive Setup** → **Configure SATA as (AHCI/RAID)**.
 - c. Select **RAID**.
 - NVMe RAID mode:
 - a. Restart the computer. When the logo screen is displayed, press F1 or Fn+F1.
 - b. Select **Devices** → **NVMe Setup** → **NVMe RAID Mode (Enabled/Disabled)**.
 - c. Select **Enabled**.
2. Press F10 or Fn+F10 to save the changes and exit.
3. Restart the computer. When the logo screen is displayed, press F1 or Fn+F1.
4. Select **Devices** → **RAIDXpert2 Configuration Utility** to select drives and configure RAID.

RAID Levels

CAUTION:

- **Only one redundant RAID array is supported by AMD-RAID. RAID1, RAID5, and RAID10 are all redundant arrays.**
- **The AMD-RAID does not support more than eight arrays, including Non-RAID array.**
- **Multiple operating systems are not supported on AMD-RAID Array. If the system is booted from an AMD-RAID bootable array, the first array in the Arrays section must be the bootable array. The system boots only from the first array in the Arrays section. Refer to “Configure RAID with RAIDXpert2 Configuration Utility” on page 29 to find the first array by viewing array details and checking the array number.**

Your computer supports the following RAID levels:

- RAID 0: striped disk array

- Provide the highest performance but no data redundancy. Data in the array is striped (distributed) across several disks.
- Support 2-8 disks.
- RAID 0 arrays are useful for holding information, such as the operating system paging file, where performance is extremely important but redundancy is not.
- RAID 1: mirrored disk array
 - Mirror data on a partition of one disk to another.
 - Support 2 disks.
 - RAID 1 arrays are useful when there are only two disks available and data integrity is more important than storage capacity.
- RAID 5: block-level striped disk array with distributed parity
 - Stripe data as well as parity, across all disks in the array.
 - Support 3-8 disks.
 - Offer exceptional read performance and redundancy.
- RAID 10: striped and mirrored disk array (a combination of RAID 0 and RAID 1)
 - Combine mirrors and stripe sets. RAID 10 allows multiple disk failures, up to 1 failure in each mirror that has been striped.
 - Support 4, 6, or 8 disks.
 - Offer better performance than a simple mirror because of the extra disks. Require twice the disk space of RAID 1 to offer redundancy.
- Volume (JBOD):
 - RAIDxpert2 Configuration Utility treats one or more disks or the unused space on a disk as a single array.
 - Support 1-8 disks.
 - Provide the ability to link-together storage from one or several disks, regardless of the size of the space on those disks. It is useful in scavenging space on disks unused by other disks in the array. It does not provide performance benefits or data redundancy. Disk failure will result in data loss.
- RAIDABLE (also known as RAID Ready):
 - Allow a RAIDABLE disk to be transformed later to RAID 0 or RAID 1.
 - Support 1 disk.

Configure RAID with RAIDxpert2 Configuration Utility

If your computer comes with the RAIDxpert2 Configuration Utility , you can follow the sections below to configure RAID.

Initialize disks

New disks and legacy disks must be initialized before they can be used to create an AMD-RAID array. Initialization writes AMD-RAID configuration information (metadata) to a disk.

CAUTION:

- **If a disk is part of an AMD-RAID array, the disk cannot be selected for initialization. To initialize the disk anyway, delete the AMD-RAID array. Data on the disk is deleted during initialization so ensure the correct disks are chosen to initialize.**
- **A legacy disk can contain valid data. When a legacy array is deleted, all data on the disk is lost.**

1. Enter the **RAIDXpert2 Configuration Utility** menu. Then, use the arrow keys to select **Physical Disk Management** and press Enter.
2. Use the arrow keys to select **Select Physical Disk Operations** and press Enter.
3. Use the arrow keys to select **Initialize Disk** and press Enter.
4. Select the disk(s) to initialize:
 - a. Use the arrow keys to select a disk and press the Space Bar or Enter. Multiple disks can be selected using this method.
 - b. Use the arrow keys to select **OK** and press Enter.
 - c. Review the warning message. If you want to proceed, use the arrow keys to select **YES** and press Enter.

Note: The Initialization process takes about 10 to 15 seconds. During initialization, a complete re-scan of all channels is done automatically.

Create arrays

Arrays can be created after the disks are initialized:

1. Enter the **RAIDXpert2 Configuration Utility** menu. Then, use the arrow keys to select **Array Management** and press Enter.
2. Use the arrow keys to select **Create Array** and press Enter.
3. Use the arrow keys to select **Select RAID Level → RAID Level** and press Enter.

Note: Some of the RAID levels might not be displayed because the number of installed storage drives varies.

4. Select the disks with which to create the array:
 - a. Use the arrow keys to select **Physical Disks** and press Enter.
 - b. Use the arrow keys to select desired disks and press the Space Bar or Enter.
 - c. Use the arrow keys to select **Apply Changes** and press Enter.
5. Refer to the table below for the default cache tag size (CTS).

Array type	Default CTS
HDD Array	64k
SSD Array	64k
All NVMe Array	256k

6. Use the arrow keys to select **Read Cache Policy** and press Enter. Select the desired read cache policy and press Enter.
7. Use the arrow keys to select **Write Cache Policy** and press Enter. Select the desired write cache policy and press Enter.
8. Use the arrow keys to select **Create Array** and press Enter.

Delete arrays

CAUTION:

- **Deleting an array permanently destroys all data that is on the array. This action cannot be recalled and it is very unlikely the data can be recovered.**
- **Do not delete the first array listed in the Arrays section, if it is the AMD-RAID bootable array. Doing this deletes the operating system and AMD-RAID files.**

1. Enter the **RAIDXpert2 Configuration Utility** menu. Then, use the arrow keys to select **Array Management** and press Enter.
2. Use the arrow keys to select **Delete Arrays** and press Enter.
3. Select the array(s) to delete:
 - a. Use the arrow keys to select the desired array or multiple arrays, then press the Space Bar or Enter to change the option to **Enabled** for deletion.
 - b. If you want to select all of the arrays, use the arrow keys to select **Check all** and press Enter.
 - c. Use the arrow keys to select **Delete Array** and press the Space Bar or Enter.
 - d. Review the warning message. If you want to proceed, press the Space Bar or Enter.
 - e. Use the arrow keys to select **Yes** to delete arrays.

View array details

This option displays the details of an array. Nothing can be changed using this menu option. It is for informational purposes only.

1. Enter the **RAIDXpert2 Configuration Utility** menu. Then, use the arrow keys to select **Array Management** and press Enter.
2. Use the arrow keys to select **Select Manage Array Properties** and press Enter.
3. Use the arrow keys to select **Select Array** and press Enter. Select the desired array and press **Enter**.
4. Use the arrow keys to select **View Associated Physical Disks** and press Enter.
5. Press the Space Bar to select one of the members of the Array.
6. Use the arrow keys to select **View Physical Disk Properties** and press Enter.
7. Information about the array is displayed below **Select Array header**:
 - Array number
 - RAID level
 - State
 - Size
 - Cache Tag Size
 - Cache settings
 - Associated physical disks
8. To view another array, press ESC twice and perform steps 2 through 7 again.
9. Press ESC to exit the main menu.

Chapter 7. Diagnostics

Use diagnostic solutions to test hardware components and report operating-system-controlled settings that interfere with the correct operation of your computer.

Lenovo diagnostic tools

This section introduces a set of Lenovo diagnostic tools.

When an error message pops up in the Windows notification area, an error code is displayed on the four-digit diagnostic display (for selected models) on the front panel, or the diagnostic indicator on the front panel turns on, do one of the following:

- If ThinkStation Diagnostics can be launched properly:
 1. Click the error message or the ThinkStation Diagnostics icon to launch the program.
 2. All events are logged locally in the program. Locate the related event and view the event log to find possible solutions.
 3. Record the error code displayed on the four-digit diagnostic display (for selected models) or in ThinkStation Diagnostics, and then decode the error at <https://www.thinkworkstationsoftware.com/?view=codes>.

Notes:

- You can download ThinkStation Diagnostics at: <https://pcsupport.lenovo.com/lenovodiagnosicsolutions/downloads>
- If you want to disable ThinkStation Diagnostics, uninstall it directly.
- If your computer does not function:
 1. Launch Lenovo PC Diagnostics installed on your smartphone (an app decodes beep errors when an error with beeps is emitted from your computers) and place your smartphone near the computer.
 2. Press Fn on your computer to emit the beep again. The app decodes the beep error at <https://www.thinkworkstationsoftware.com/?view=codes> and shows possible solutions on the smartphone.

Notes: Download Lenovo PC Diagnostics from app stores or the Le Store Web site and install it on your smartphone:

- Le Store or Google Play Store (Android)
- iTunes App Store (iOS)
- Le Store Web site <https://www.lenovomm.com/appdetail/com.lenovo.lenovoworkstationdiagnostics/85>

For more information, go to:

- <https://pcsupport.lenovo.com/lenovodiagnosicsolutions>
- <https://www.thinkworkstationsoftware.com/?view=diags>

Use the Vantage app

The Vantage app is preinstalled on your computer. To diagnose problems with the Vantage app:

1. Type Vantage in the Windows search box and press Enter.
2. Follow the on-screen instructions and run a hardware scan.

If you are unable to isolate and resolve the problem after running the Vantage app, save and print the log files created by the program. You might need the log files when you speak to a Lenovo technical support representative.

Chapter 8. CRU replacement

What is CRU

Customer Replaceable Units (CRUs) are parts that can be upgraded or replaced by the customer. Lenovo computers contain the following types of CRUs:

- **Self-service CRUs:** Refer to parts that can be installed or replaced easily by customer themselves or by trained service technicians at an additional cost.
- **Optional-service CRUs:** Refer to parts that can be installed or replaced by customers with a greater skill level. Trained service technicians can also provide service to install or replace the parts under the type of warranty designated for the customer's machine.

If you intend on installing the CRU, Lenovo will ship the CRU to you. CRU information and replacement instructions are shipped with your product and are available from Lenovo at any time upon request. You might be required to return the defective part that is replaced by the CRU. When return is required: (1) return instructions, a prepaid shipping label, and a container will be included with the replacement CRU; and (2) you might be charged for the replacement CRU if Lenovo does not receive the defective CRU within thirty (30) days of your receipt of the replacement CRU. For full details, see the Lenovo Limited Warranty documentation at:

https://www.lenovo.com/warranty/llw_02

Refer to the following CRU list for your computer.

Self-service CRUs

- Computer cover
- Cover presence switch
- Flex module*
- Front-access storage enclosure*
- Front fan assembly
- Front panel I/O cage
- Graphics card dongle*
- Hard disk drive
- ID badge
- Keyboard*
- Multi-drive conversion kit*
- Memory module
- Memory module active cooler and duct
- Mouse*
- Power cord
- Power supply assembly
- Rear fan assembly
- Slim optical drive*
- Slim-optical-drive bracket*
- Slim-optical-drive adapter*

- Storage drive cage*
- Super capacitor module*
- Wi-Fi antenna*

Optional-service CRUs

- Graphics card*
- M.2 solid-state drive*
- M.2 solid-state drive heat sink*
- PCIe card*

* for selected models

Replace a CRU

Follow the replacement procedure to replace a CRU.

ID badge

Prerequisite

Before you start, read *Generic Safety and Compliance Notices*, and print the following instructions.

Replacement procedure

1. Remove the ID badge.

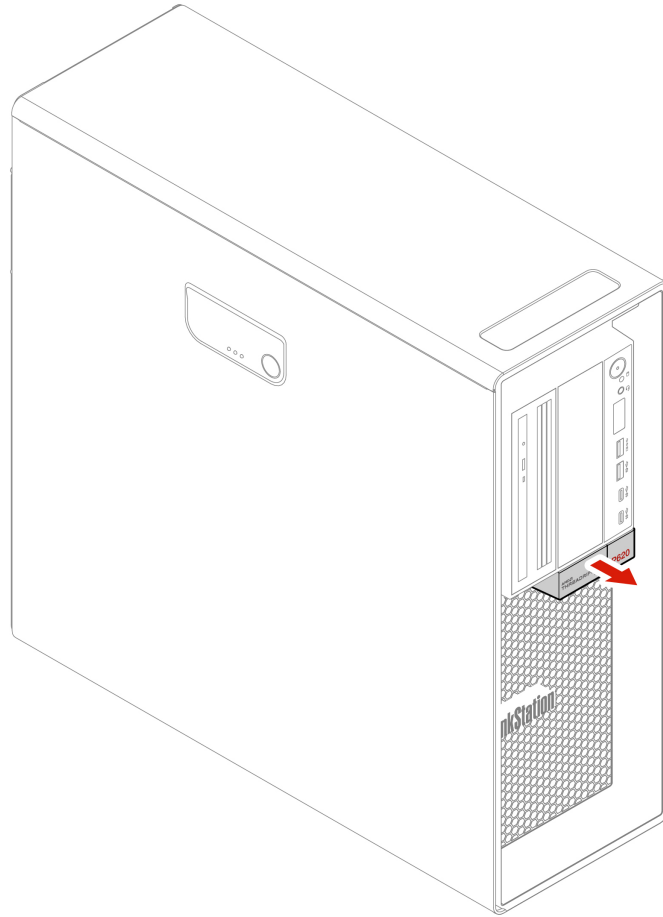

2. Install the ID badge.

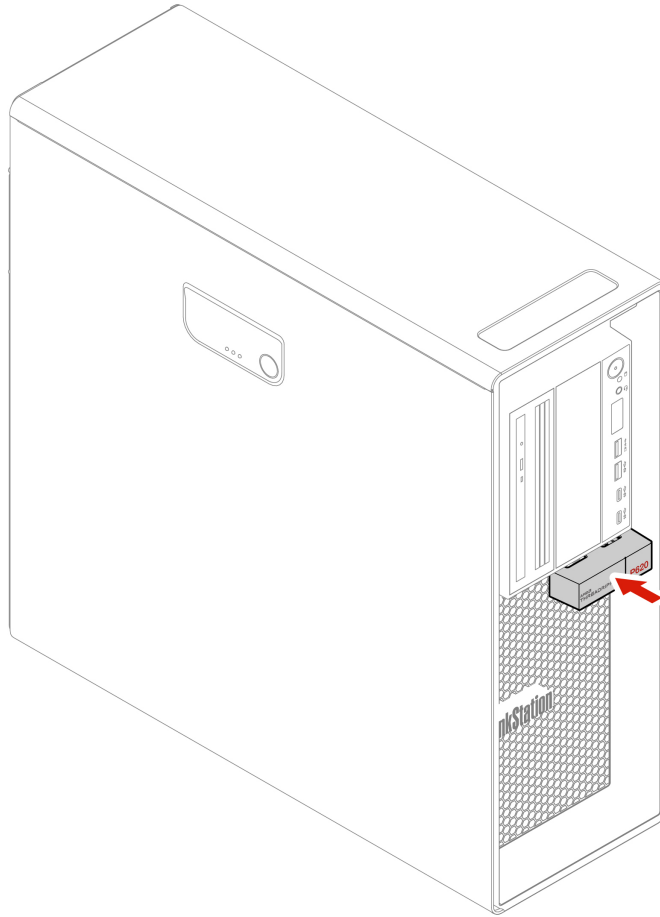

Wi-Fi antenna

Prerequisite

Before you start, read *Generic Safety and Compliance Notices*, and print the following instructions.

Replacement procedure

1. Remove the Wi-Fi antenna.

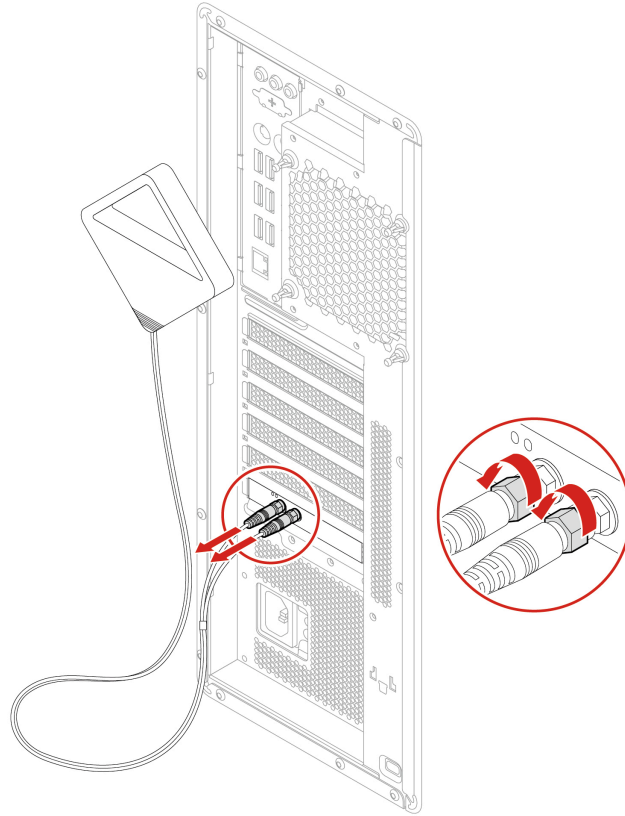

2. Install the Wi-Fi antenna.

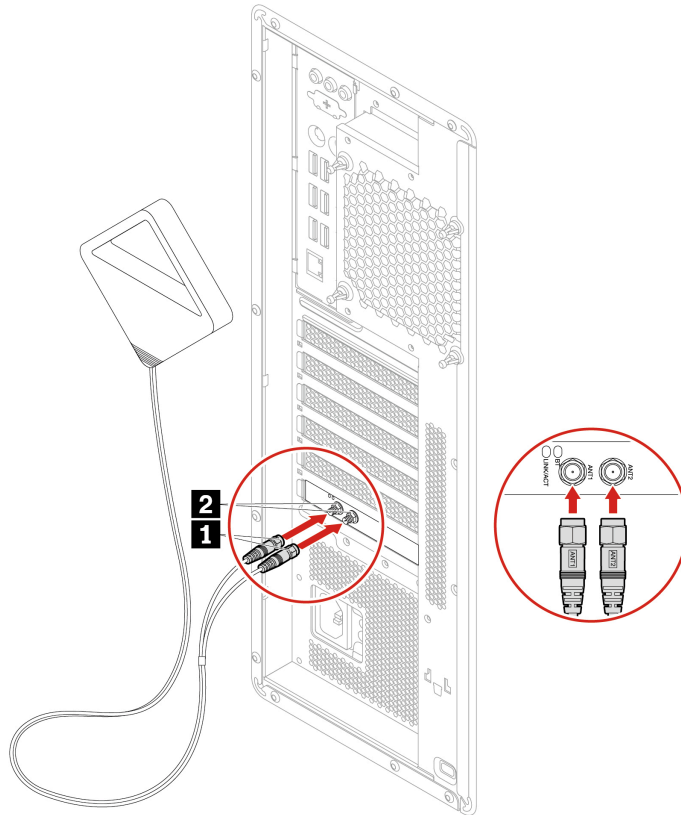

3. Tighten the Wi-Fi antenna cable connectors to secure them to the rear of the computer.

Computer cover

Prerequisite

Before you start, read *Generic Safety and Compliance Notices*, and print the following instructions.



Before you open the computer cover, turn off the computer and wait several minutes until the computer is cool.

Replacement procedure

1. Remove any media from the drives and turn off all connected devices and the computer.
2. Disconnect all power cords from electrical outlets and disconnect all cables from the computer.
3. Unlock any locking device that secures the computer cover.
4. Remove the computer cover.

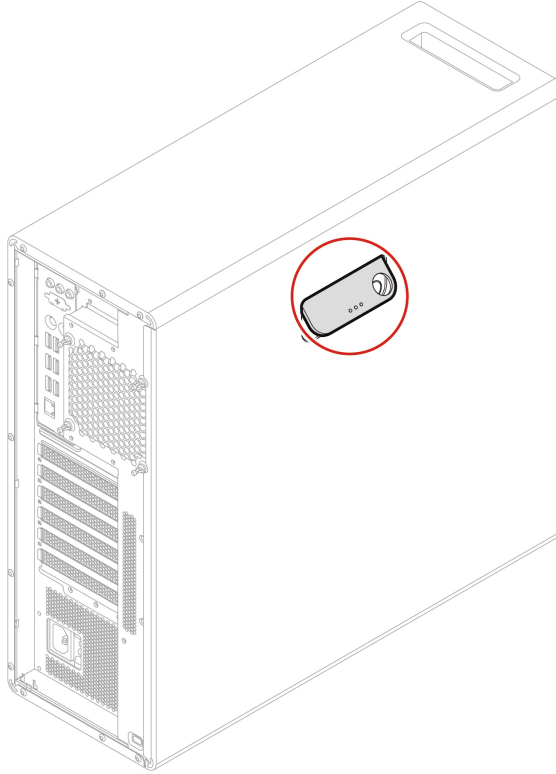
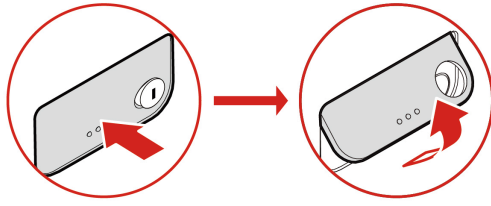

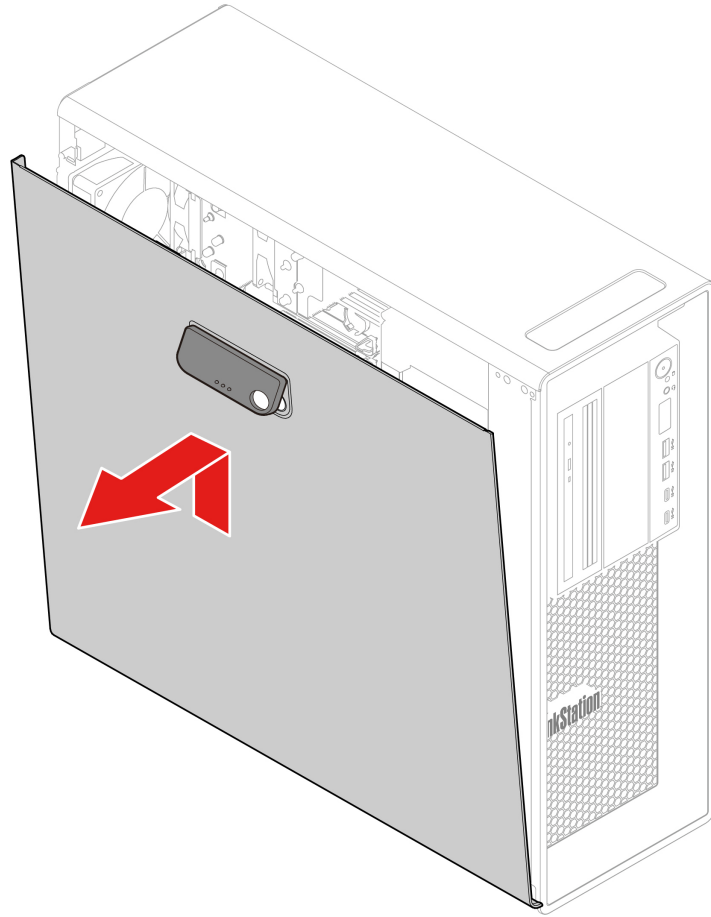

5. Install the computer cover.

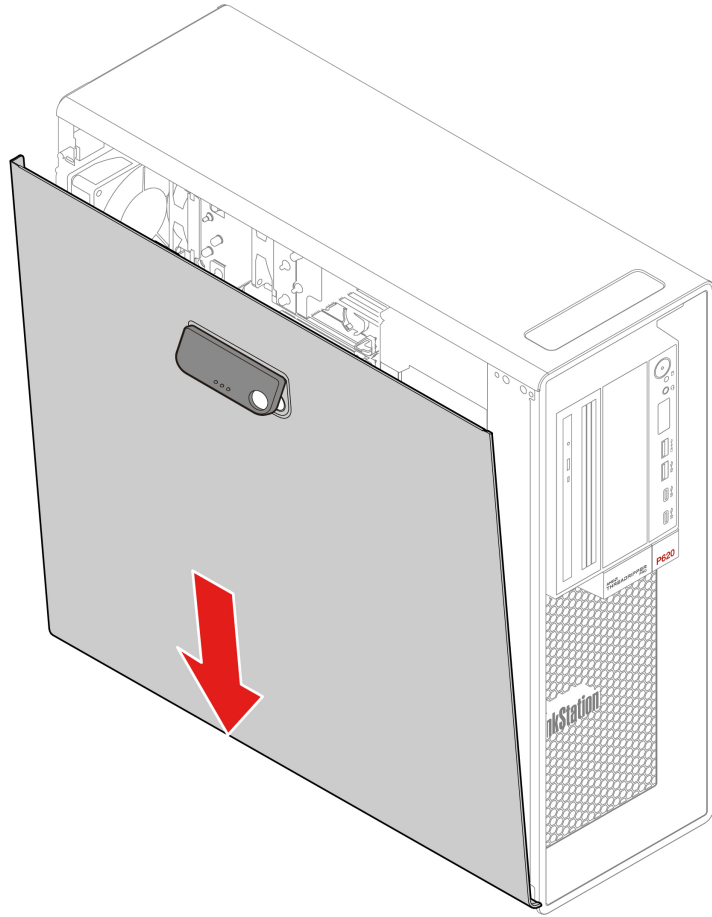

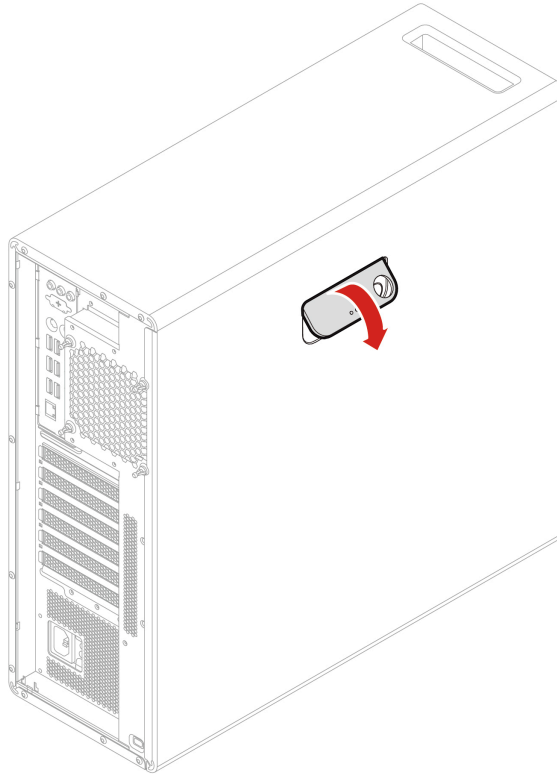

6. Reconnect the power cord and all disconnected cables to the computer.

Note: If a locking device is available, use it to lock the computer.

Device in the flex bay

Prerequisite

Before you start, read *Generic Safety and Compliance Notices*, and print the following instructions.

The flex bay of your computer supports the following devices:

- Flex module
- Front-access storage enclosure
- Multi-drive conversion kit
- Slim-optical-drive adapter

Note: The following instructions on how to remove or install a slim-optical-drive adapter also apply to other supported devices in the flex bay.

Replacement procedure

1. Remove the computer cover. See “Computer cover” on page 39.
2. Locate the flex bay. See “Internal storage drives” on page 7.
3. Disconnect the signal cable and the power cable from the rear of the slim optical drive.

Note: If you are removing other supported devices from the flex bay, disconnect any additional cables first.

4. Remove the slim-optical-drive adapter.

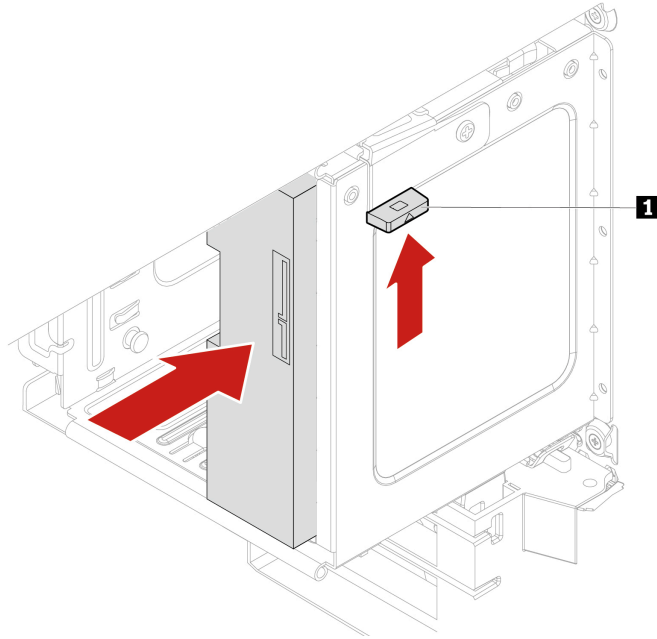

5. Remove the slim optical drive from the failing adapter and install the slim optical drive into the new adapter. See “Device in the multi-drive conversion kit” on page 49.
6. If you are installing a slim-optical-drive adapter into the flex bay with a plastic shield installed, press the clip as shown to remove the plastic shield. If there is a metal static shield installed in the flex bay, remove the metal static shield.

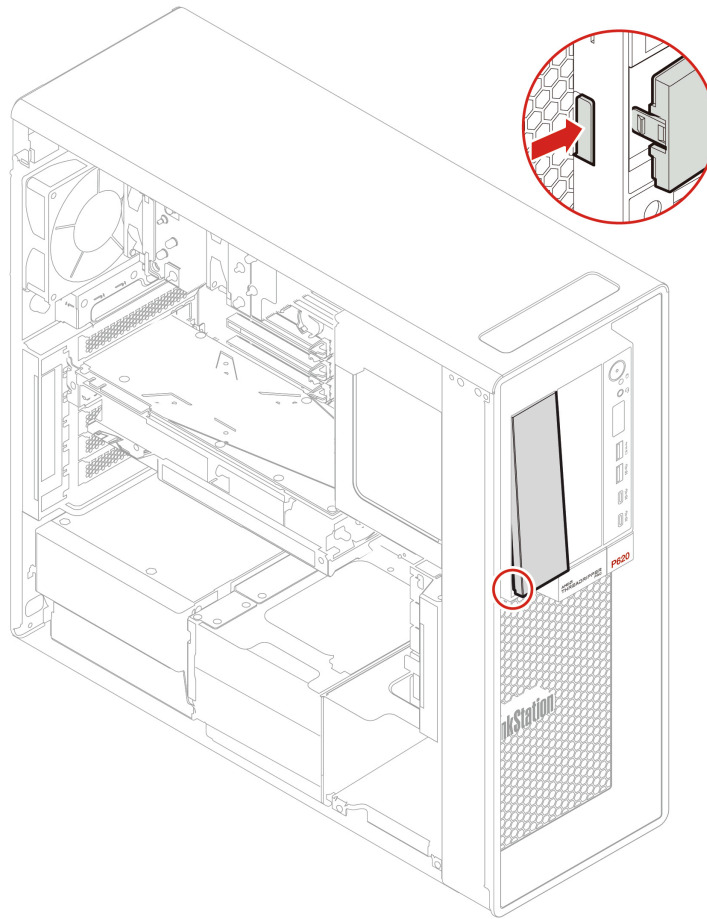

7. Install the slim-optical-drive adapter.

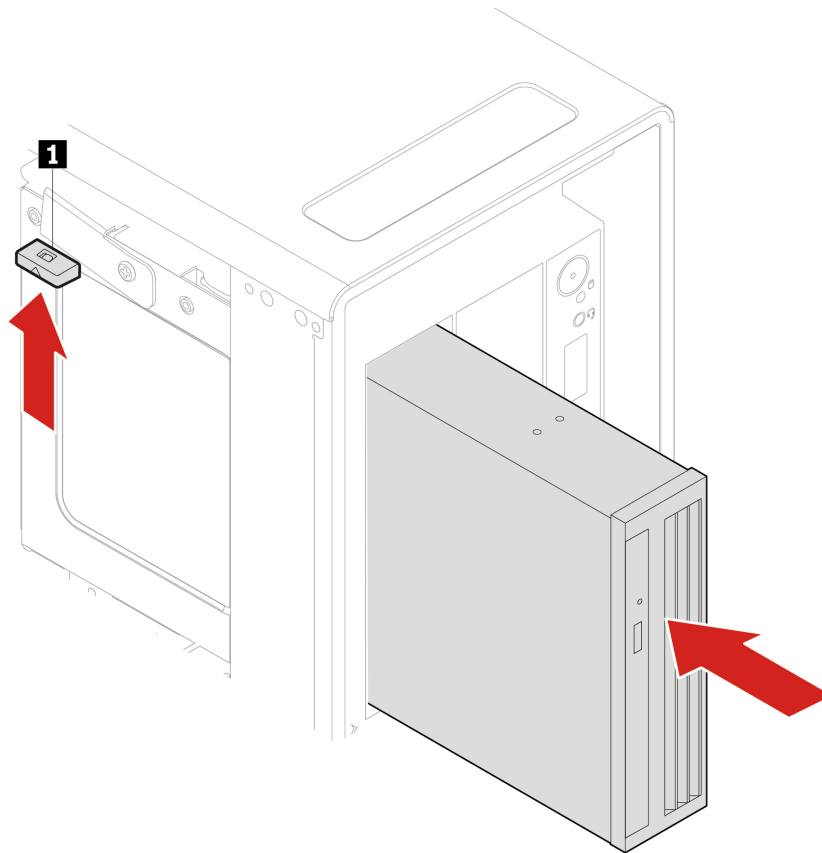

8. Connect the signal cable and the power cable to the slim optical drive.

Note: Reconnect any cables removed from other supported devices.

9. Reinstall all removed parts. Then, reconnect the power cord and all disconnected cables to the computer.

Storage drive in the front-access storage enclosure

Prerequisite

Before you start, read *Generic Safety and Compliance Notices*, and print the following instructions.

Attention: The internal storage drive is sensitive. Inappropriate handling might cause damage and permanent loss of data. When handling the internal storage drive, observe the following guidelines:

- Replace the internal storage drive only for upgrade or repair. The internal storage drive is not designed for frequent changes or replacement.
- Before replacing the internal storage drive, make a backup copy of all the data that you want to keep.
- Do not touch the contact edge of the internal storage drive. Otherwise, the internal storage drive might get damaged.
- Do not apply pressure to the internal storage drive.
- Do not make the internal storage drive subject to physical shocks or vibration. Put the internal storage drive on a soft material, such as cloth, to absorb physical shocks.

You can install or replace a storage drive in the front-access storage enclosure. The storage drive also can be hot-swappable, which means that you can install or replace the drive without even turning off your

computer. Therefore, lock the enclosure cover to prevent the unexpected removal. The keys are attached at the rear of the computer. Store the keys in a secure place.

The storage drive in the front-access storage enclosure is hot-swappable only when the following requirements are met:

- The SATA cable of the front-access storage enclosure is connected to the eSATA connector on the system board. To verify the cable connection, see “System board illustration” on page 4 for more information.
- The operating system of your computer does not reside on the storage drive installed in the front-access storage enclosure.

Attention: If any of the above requirements are not met, do not remove or install the storage drive when the computer is turned on. Otherwise, data on the storage drive might get damaged.

Replacement procedure

1. Remove the computer cover. See “Computer cover” on page 39.
2. Locate the flex bay. See “Internal storage drives” on page 7.
3. Before removing an old 3.5-inch storage drive, safely eject the old storage drive from the operating system first. For more information, see the Windows help system.
4. Unlock the enclosure cover with the provided key as shown. Press the notch **a** to open the enclosure cover.

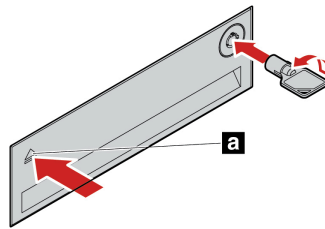

5. Remove the bracket out of the front-access storage enclosure.

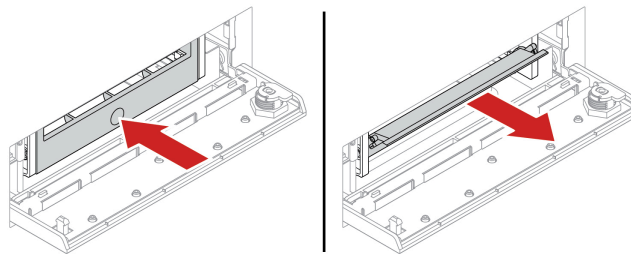

6. Remove the 3.5-inch storage drive from the bracket.

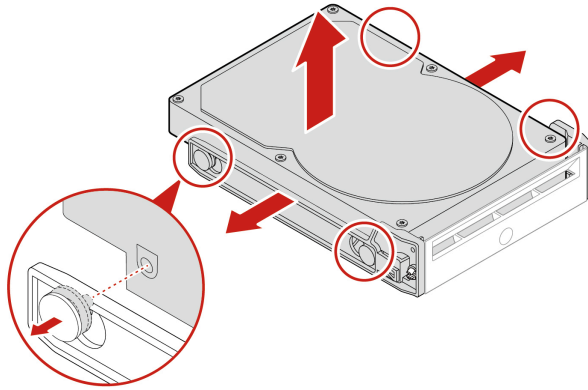

7. Install a new 3.5-inch storage drive.

Notes:

- Ensure that the circuit board faces downward and the connectors face toward the rear of the bracket.
- Do not touch the circuit board on the storage drive during operation.

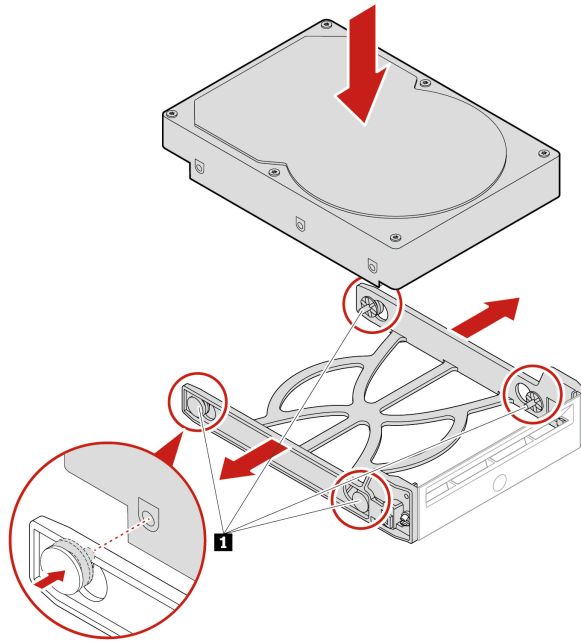

8. Install the new 3.5-inch storage drive into the front-access storage enclosure. Press the notch to secure the enclosure cover and lock the enclosure cover with the key.

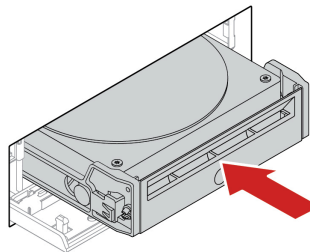

9. Reinstall all removed parts. Then, reconnect the power cord and all disconnected cables to the computer.

Device in the multi-drive conversion kit

Prerequisite

Before you start, read *Generic Safety and Compliance Notices*, and print the following instructions.

The multi-drive conversion kit (hereafter referred to as kit) might be equipped with either one or both of the following components:

- Slim optical drive
- Storage drive

Slim optical drive

1. Remove the computer cover. See “Computer cover” on page 39.
2. Ensure that all the cables are disconnected from the kit. Remove the kit from the front of the computer.
3. Remove the slim optical drive with the bracket from the kit.

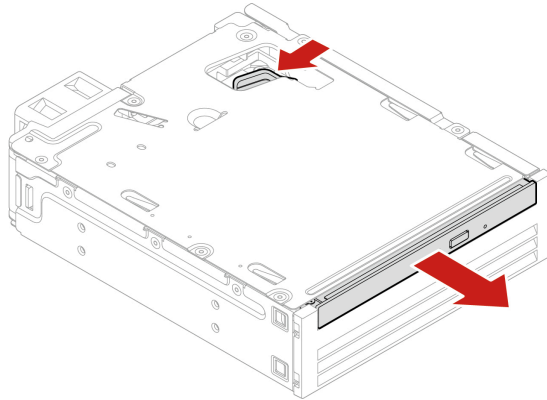

4. Remove the bracket from the slim optical drive.

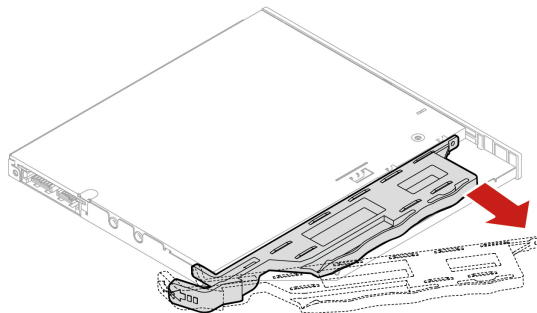

5. Install the bracket to the new slim optical drive.

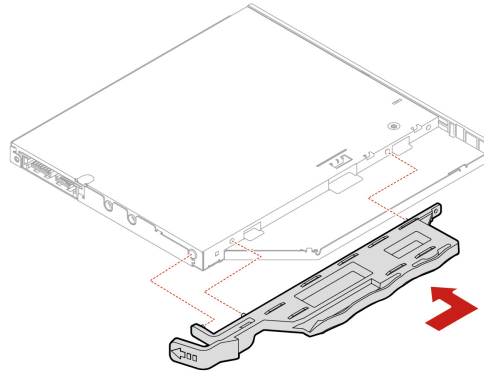

6. Install the slim optical drive with the bracket into the kit.

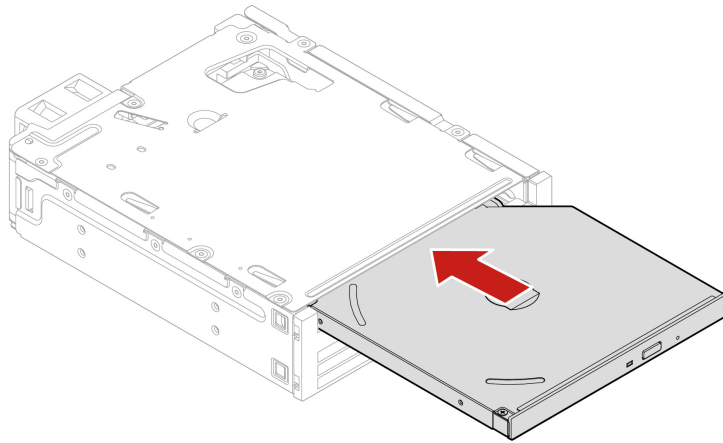

7. Slide the kit into the flex bay and reconnect the disconnected cables to the kit.

8. Reinstall all removed parts. Then, reconnect the power cord and all disconnected cables to the computer.

3.5-inch storage drive

1. Remove the computer cover. See “Computer cover” on page 39.
2. Ensure that all the cables are disconnected from the kit. Remove the kit from the front of the computer.
3. Open the rear cover of the kit.

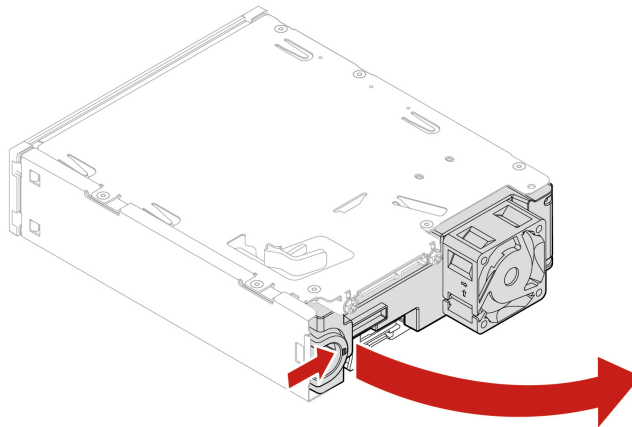

4. Remove the conversion bracket from the kit.

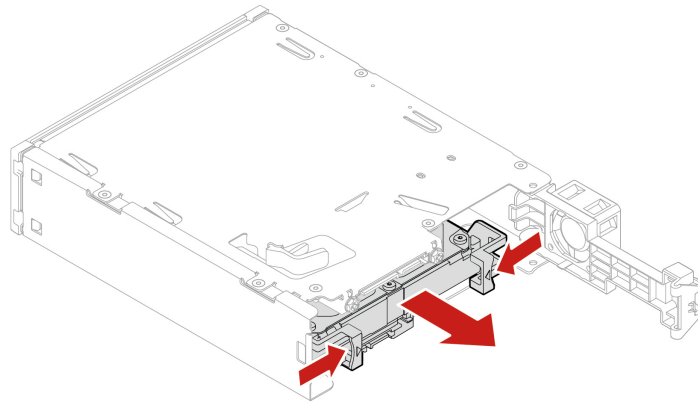

5. Remove the 3.5-inch storage drive from the conversion bracket. Do not touch the circuit board **1** on the drive.

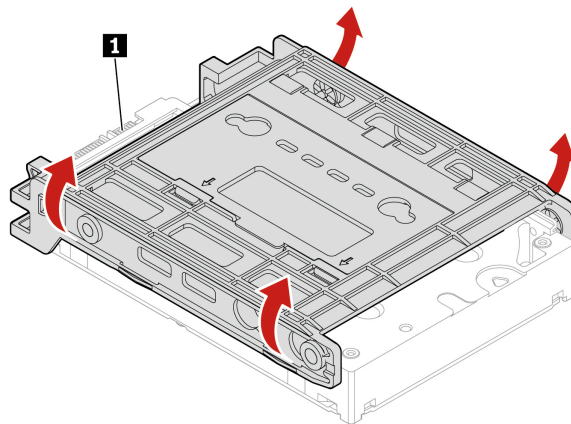

6. To install a 3.5-inch storage drive, ensure that the conversion bracket is unfolded. To unfold the bracket:
a. Remove pins **1** and install them into slots **2**.

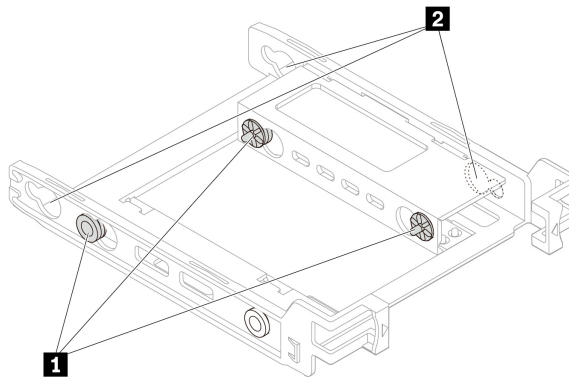

b. Release tabs **1**, **2**, and **3** from the corresponding slots.

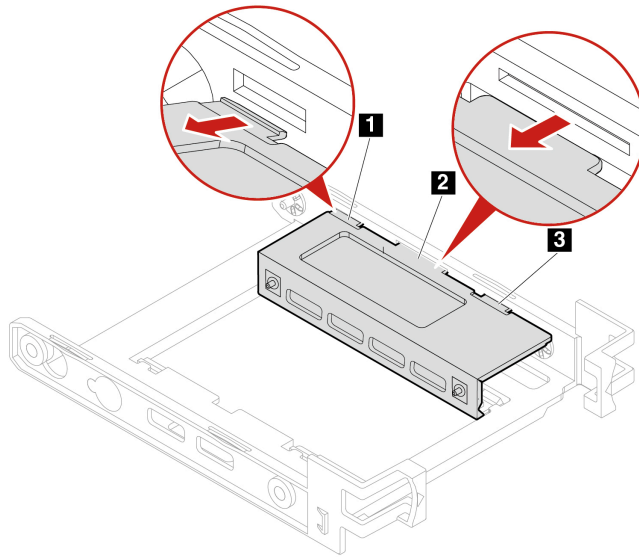

c. Unfold the bracket as shown.

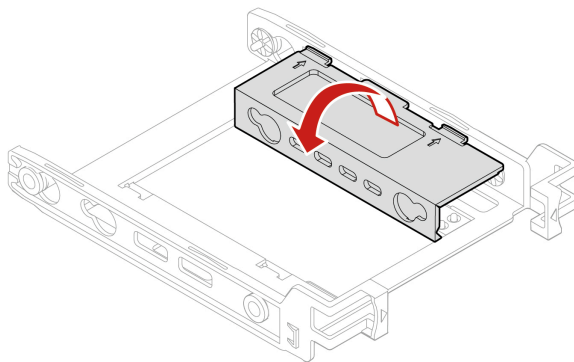

d. Insert tabs **1**, **2**, and **3** into the corresponding slots. Ensure that the tabs are secured in place.

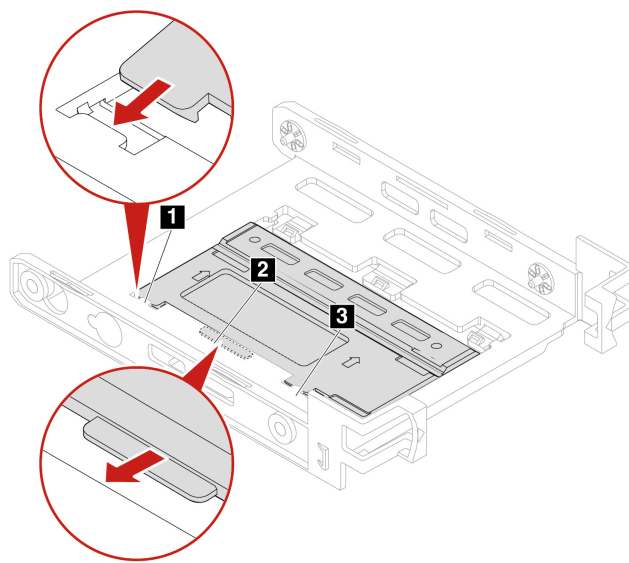

7. Install the new 3.5-inch storage drive into the bracket. Do not touch the circuit board **5** on the drive.

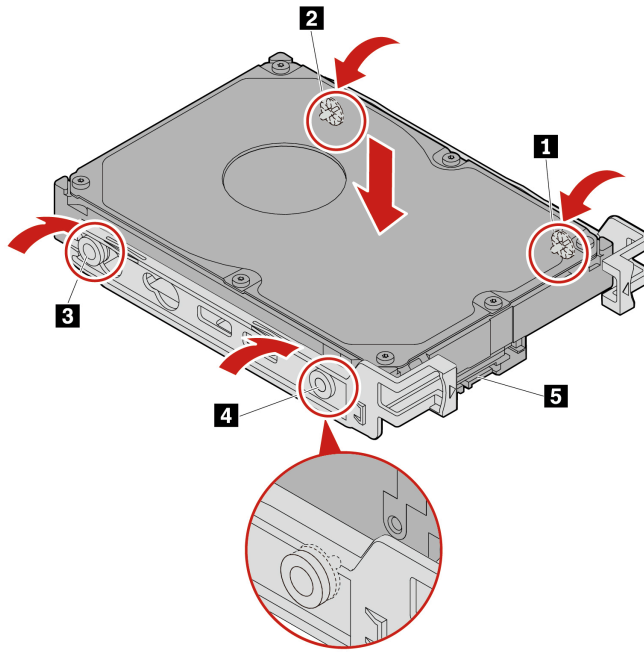

8. Install the new 3.5-inch storage drive with the bracket into the kit.

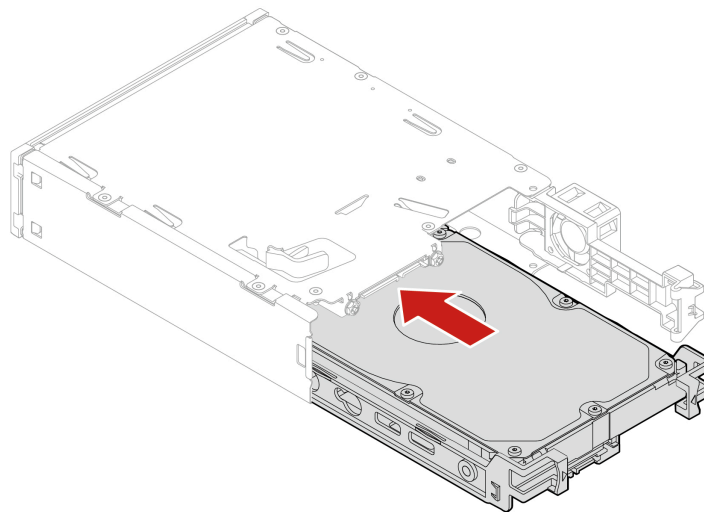

9. Close the rear cover of the kit.

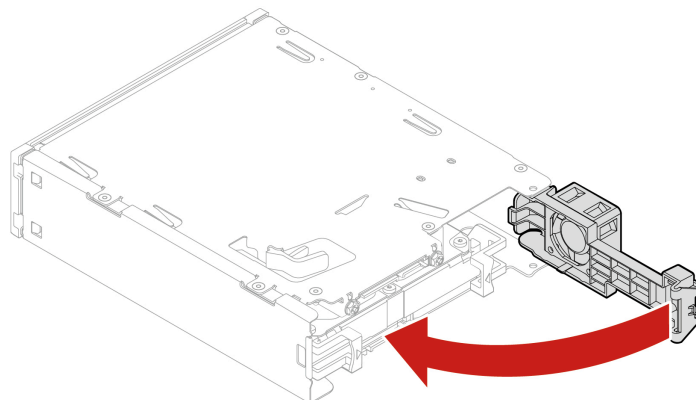

10. Slide the kit into the flex bay and reconnect the disconnected cables to the kit.
11. Reinstall all removed parts. Then, reconnect the power cord and all disconnected cables to the computer.

Front panel I/O cage

Prerequisite

Before you start, read *Generic Safety and Compliance Notices*, and print the following instructions.

Replacement steps

1. Remove the computer cover. See “Computer cover” on page 39.
2. Lay the computer on its side for easier access to the front panel I/O cage.
3. Remove the front panel I/O cage.

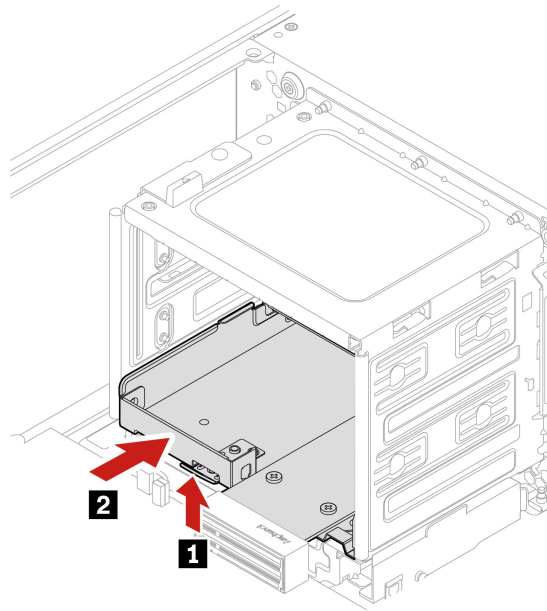

4. Install the front panel I/O cage.

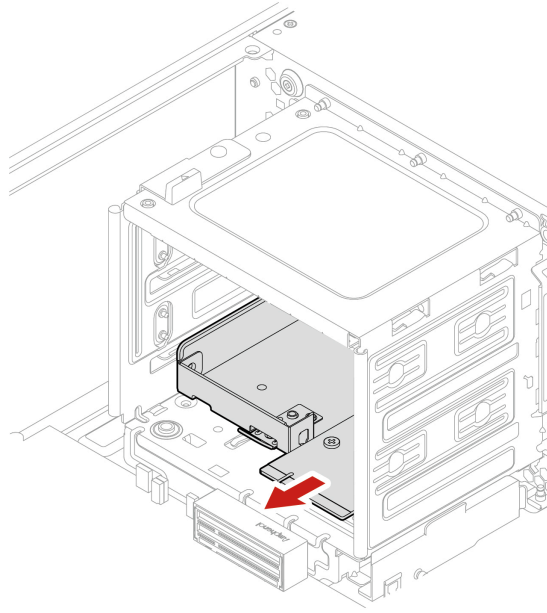

5. Reinstall all removed parts. Then, reconnect the power cord and all disconnected cables to the computer.

Cover presence switch

Prerequisite

Before you start, read *Generic Safety and Compliance Notices*, and print the following instructions.

Replacement procedure

1. Remove the computer cover. See “Computer cover” on page 39.
2. Disconnect the cover presence switch cable from the system board. See “System board illustration” on page 4.
3. Remove the cover presence switch.

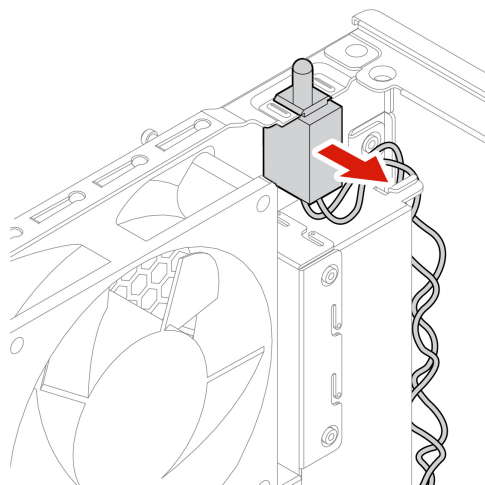

4. Install a new cover presence switch.

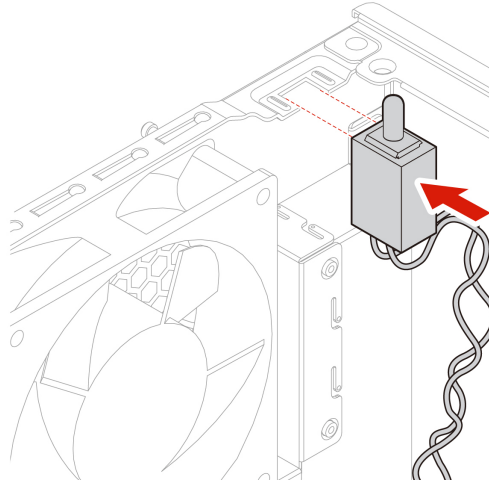

5. Connect the cable of the new cover presence switch to the cover presence switch connector on the system board.
6. Reinstall all removed parts. Then, reconnect the power cord and all disconnected cables to the computer.

Storage drive in a storage drive bay

Prerequisite

Before you start, read *Generic Safety and Compliance Notices*, and print the following instructions.

Attention: The internal storage drive is sensitive. Inappropriate handling might cause damage and permanent loss of data. When handling the internal storage drive, observe the following guidelines:

- Replace the internal storage drive only for upgrade or repair. The internal storage drive is not designed for frequent changes or replacement.
- Before replacing the internal storage drive, make a backup copy of all the data that you want to keep.
- Do not touch the contact edge of the internal storage drive. Otherwise, the internal storage drive might get damaged.
- Do not apply pressure to the internal storage drive.
- Do not make the internal storage drive subject to physical shocks or vibration. Put the internal storage drive on a soft material, such as cloth, to absorb physical shocks.

Replacement procedure

1. Remove the computer cover. See “Computer cover” on page 39.
2. Locate the storage drive bay. See “Internal storage drives” on page 7.
3. Disconnect all the cables from the storage drive.
4. Remove the conversion bracket out of the storage drive bay.

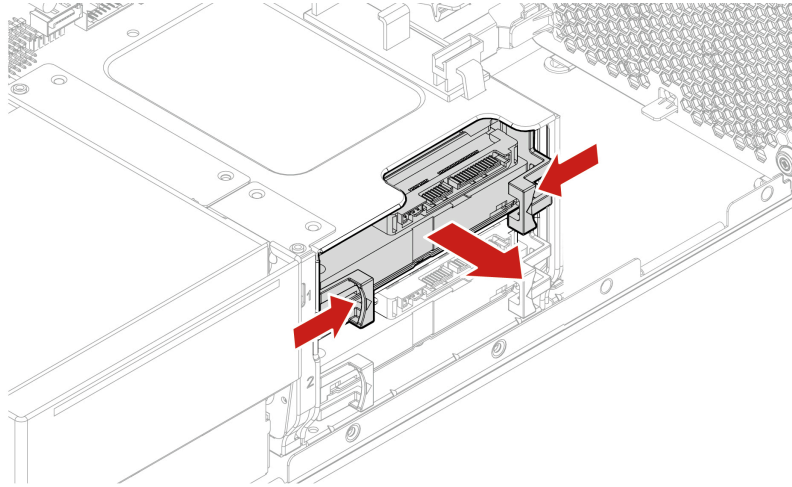

5. Remove the 3.5-inch storage drive from the bracket. Do not touch the circuit board **1** on the drive.

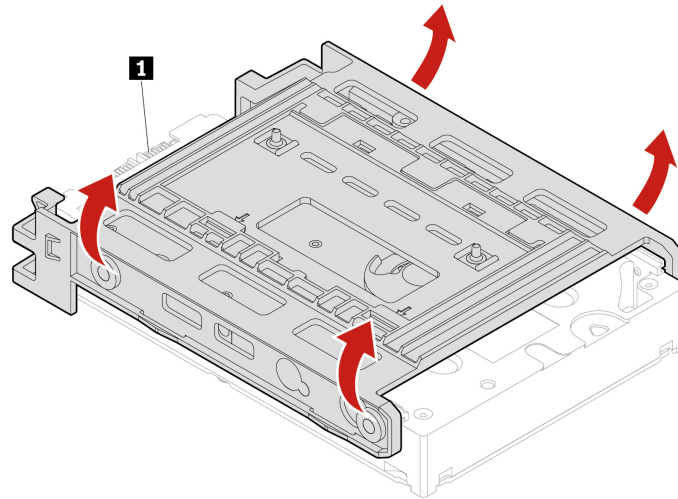

6. To install a 3.5-inch storage drive, ensure that the conversion bracket is unfolded. To unfold the bracket:
a. Remove the pin **1** and install it into the slot **2**.

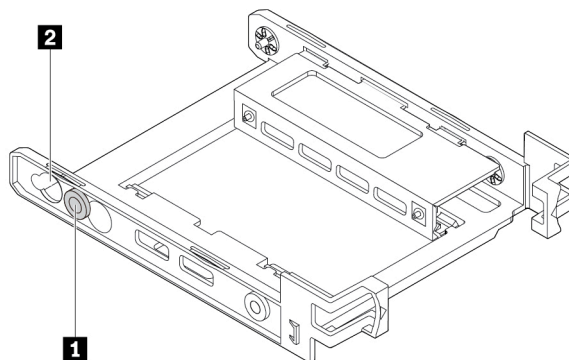

b. Release tabs **1**, **2**, and **3** from the corresponding slots.

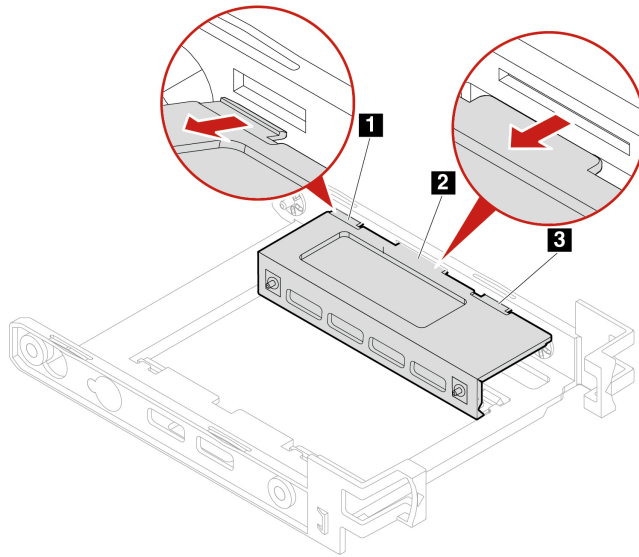

c. Unfold the bracket as shown.

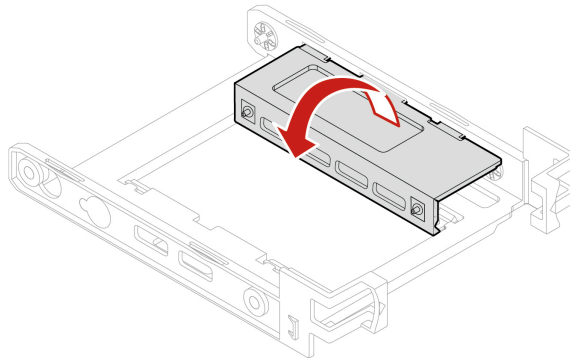

d. Insert tabs **1**, **2**, and **3** into the corresponding slots. Ensure that the tabs are secured in place.

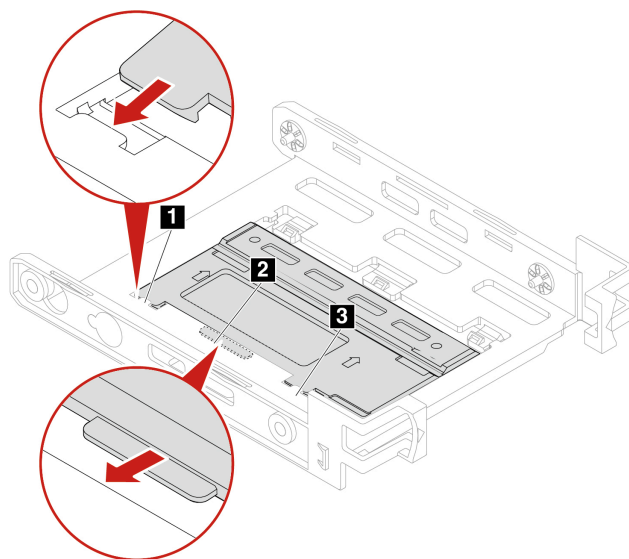

7. Install the new 3.5-inch storage drive into the bracket. Do not touch the circuit board **5** on the drive.

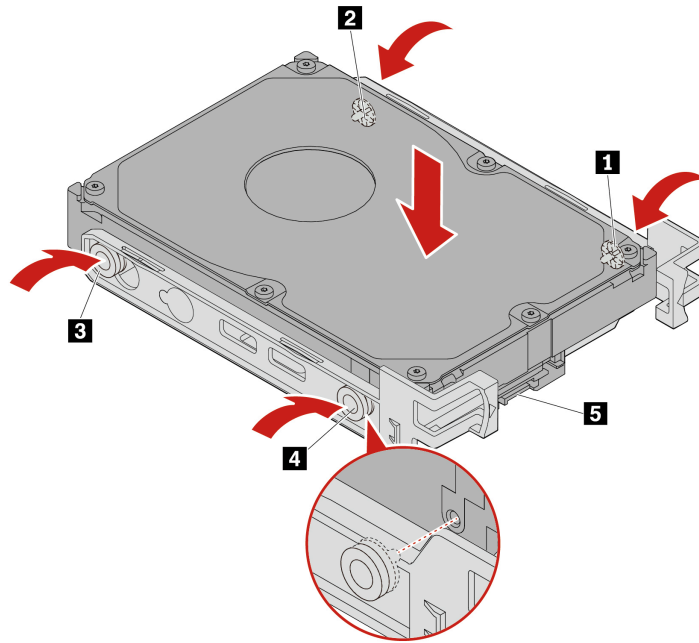

8. Install the new 3.5-inch storage drive with the conversion bracket into the storage drive bay.

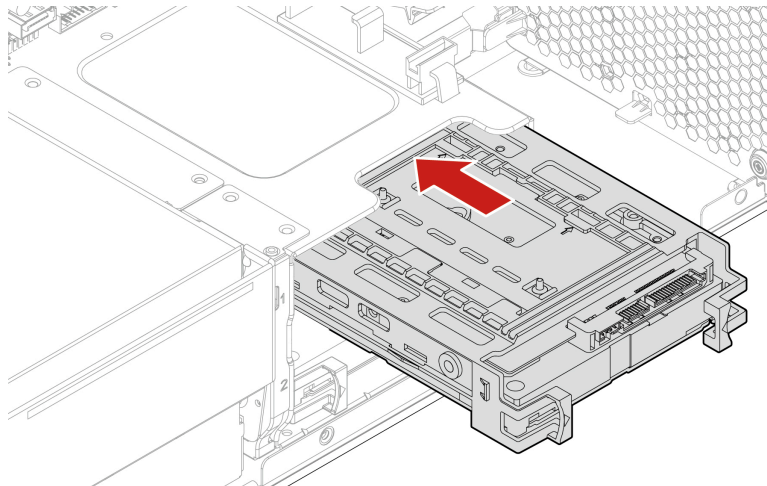

9. Connect the signal cable and the power cable to the new storage drive.

10. Reinstall all removed parts. Then, reconnect the power cord and all disconnected cables to the computer.

Storage drive cage

Prerequisite

Before you start, read *Generic Safety and Compliance Notices*, and print the following instructions.

Your computer might come with an optional storage drive cage.

Replacement procedure

1. Remove the computer cover. See “Computer cover” on page 39.
2. Remove the front fan assembly. See “Front fan assembly” on page 85.

3. Locate the storage drive cage. See “Internal storage drives” on page 7..
4. Disconnect all the cables from the storage drive.
5. Remove the storage drives out of the storage drive cage. See “Storage drive in a storage drive bay” on page 56.
6. Remove the storage drive cage.

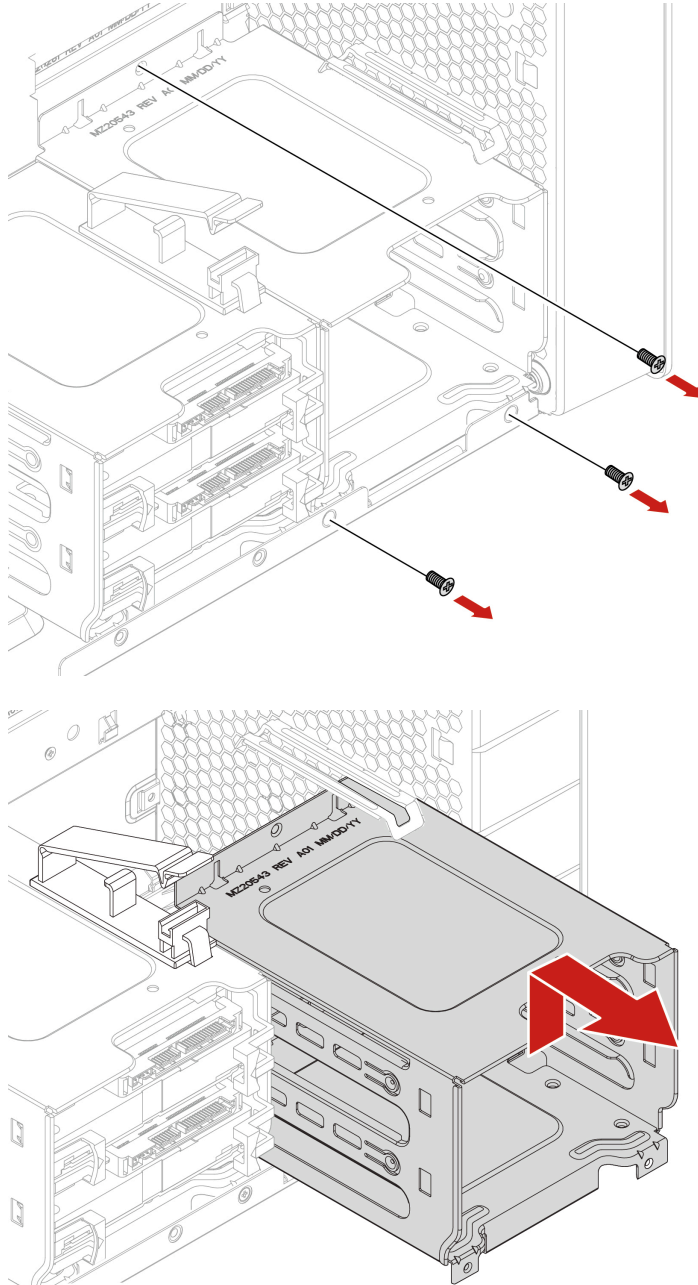

7. Install a storage drive cage:
 - a. Place the upper edge of the storage drive cage under the front-fan-assembly retainer as shown.

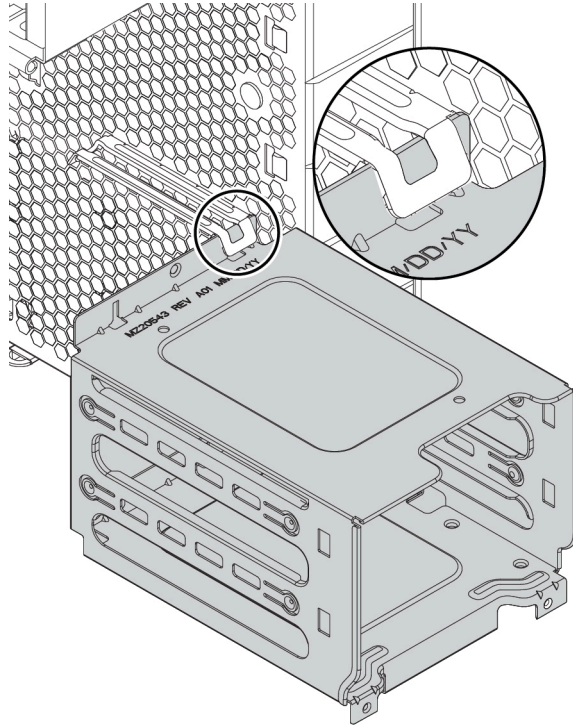

- b. Gently push the storage drive cage inward until it cannot be pushed any further. Then press the drive cage downward.

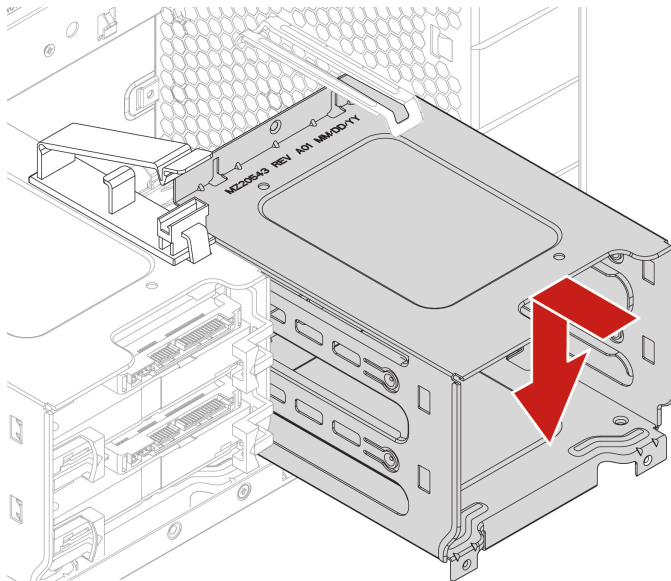

- c. Secure the storage drive cage with three screws.

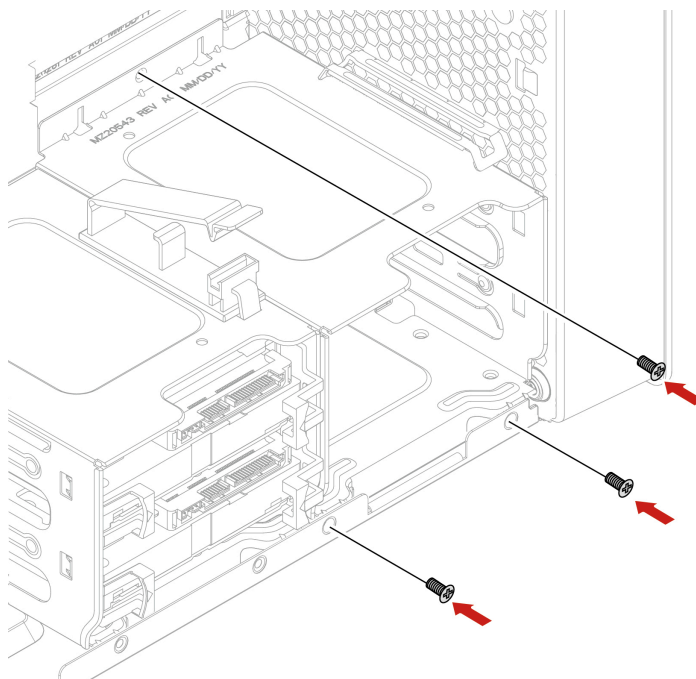

8. Slide the storage drives into the storage drive cage. Reconnect the removed cables to the storage drives. See “Storage drive in a storage drive bay” on page 56.
9. Reinstall all removed parts. Then, reconnect the power cord and all disconnected cables to the computer.

M.2 solid-state drive

Prerequisite

Before you start, read *Generic Safety and Compliance Notices*, and print the following instructions.

Attention: The internal storage drive is sensitive. Inappropriate handling might cause damage and permanent loss of data. When handling the internal storage drive, observe the following guidelines:

- Replace the internal storage drive only for upgrade or repair. The internal storage drive is not designed for frequent changes or replacement.
- Before replacing the internal storage drive, make a backup copy of all the data that you want to keep.
- Do not touch the contact edge of the internal storage drive. Otherwise, the internal storage drive might get damaged.
- Do not apply pressure to the internal storage drive.
- Do not make the internal storage drive subject to physical shocks or vibration. Put the internal storage drive on a soft material, such as cloth, to absorb physical shocks.

An M.2 solid-state drive can be installed on the system board or on an M.2 solid-state drive PCIe adapter.

M.2 solid-state drive on the system board

1. Remove the computer cover. See “Computer cover” on page 39.
2. Lay the computer on its side for easier access to the M.2 solid-state drive slots.
3. Locate the M.2 solid-state drive. See “Internal storage drives” on page 7.
4. Remove the memory cooler and duct. See “Internal storage drives” on page 7.
5. Remove the heat sink for the M.2 solid-state drive.

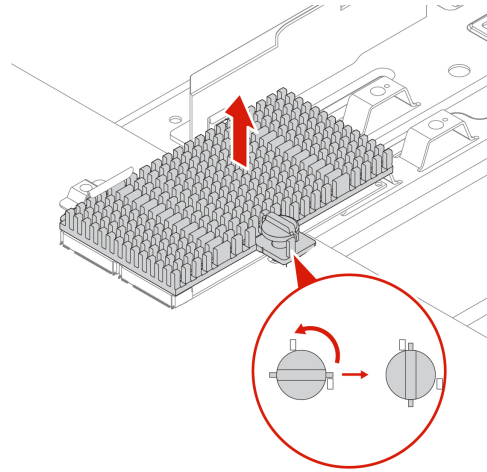

6. Remove the M.2 solid-state drive.

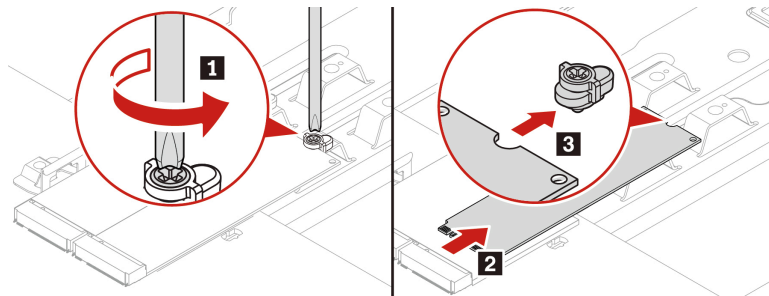

7. Install an M.2 solid-state drive.

Notes:

- Do not touch the circuit board of the M.2 solid-state drive.
- If only one M.2 solid-state drive is installed, ensure that the drive is installed in the M.2 solid-state drive slot 1 (19). See “System board illustration” on page 4.

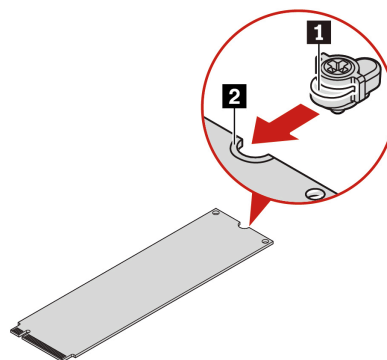

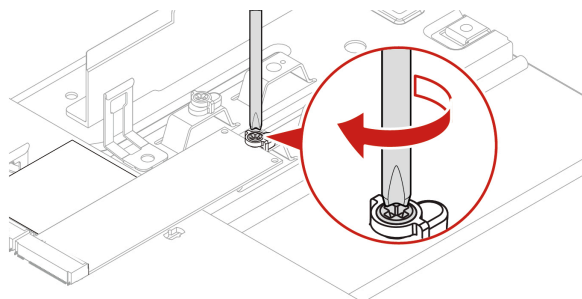
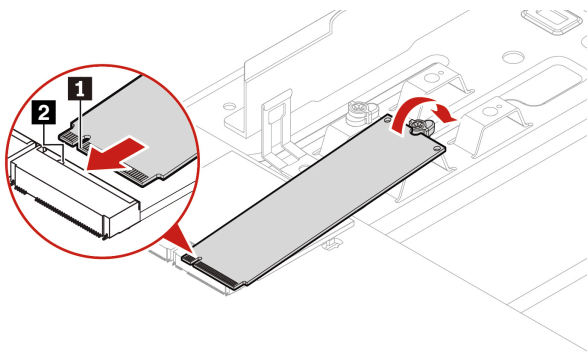

8. Install and secure the heat sink for the M.2 solid-state drive.

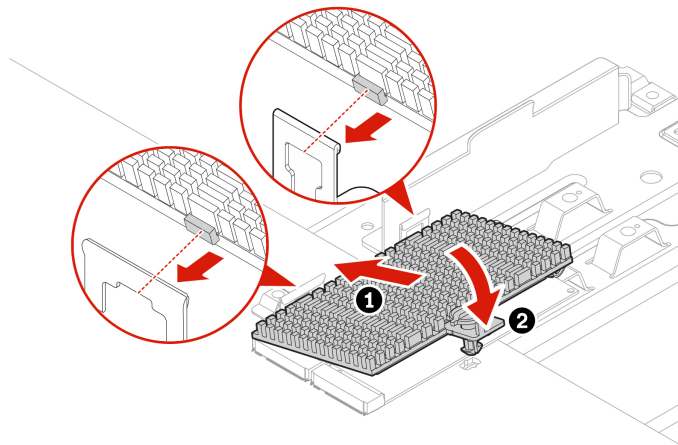

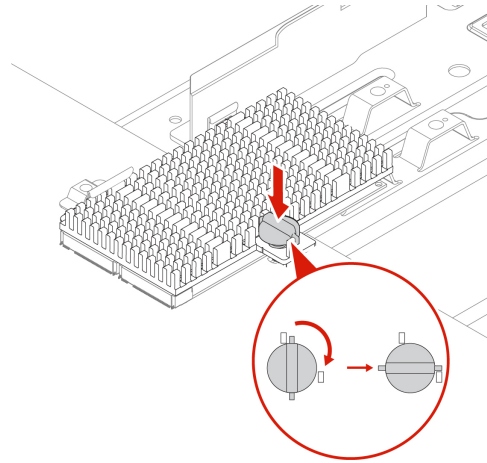

9. Reinstall all removed parts. Then, reconnect the power cord and all disconnected cables to the computer.

M.2 solid-state drive in an M.2 solid-state drive PCIe adapter

- Type 1

Install M.2 solid-state drives in the alphabetic order as shown.

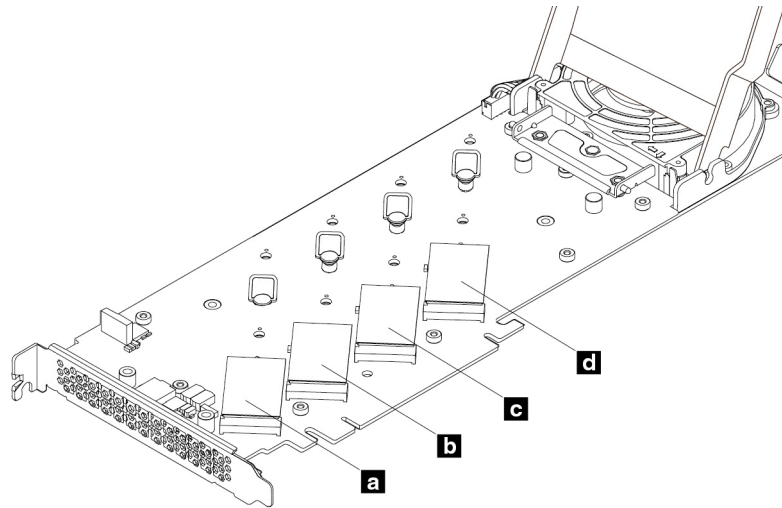

1. Remove the computer cover. See “Computer cover” on page 39.
2. Remove the M.2 solid-state drive PCIe adapter from the PCIe card slot. See “Full-length PCIe card” on page 80.
3. Open the cover.

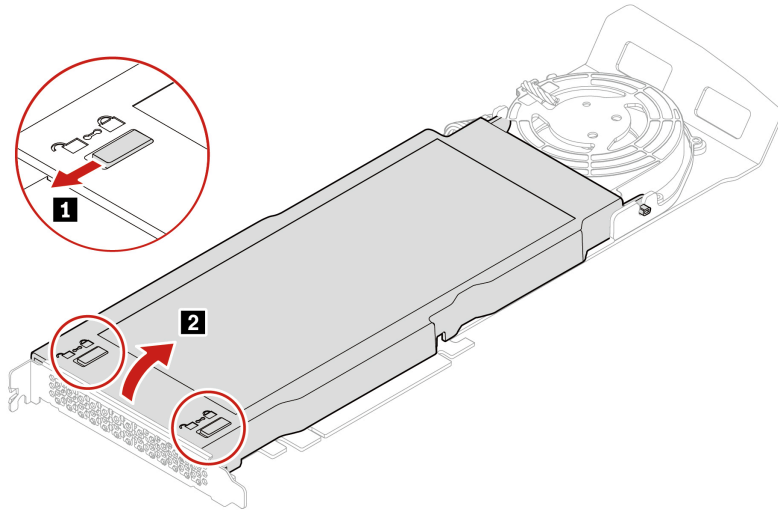

4. Remove the M.2 solid-state drive heat sink.

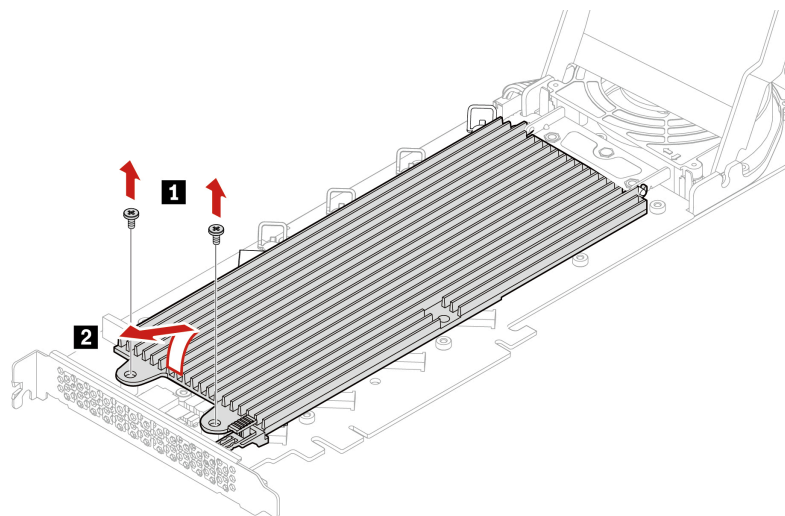

5. Pull the handle of the retention latch outward to release the M.2 solid-state drive. Then, remove the M.2 solid-state drive from the PCIe adapter.

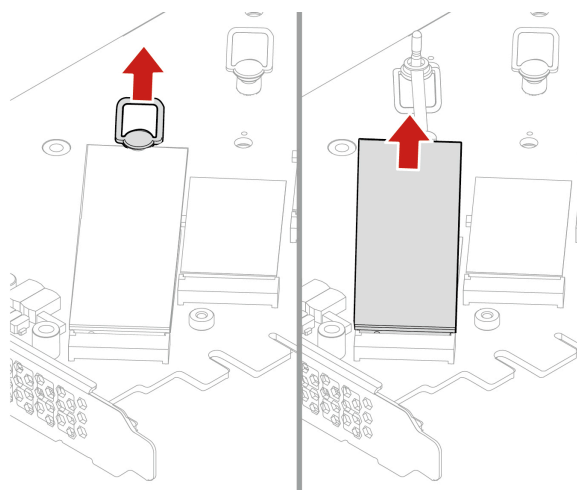

6. If necessary, move the retention latch to an appropriate location to suit the length of the new M.2 solid-state drive.

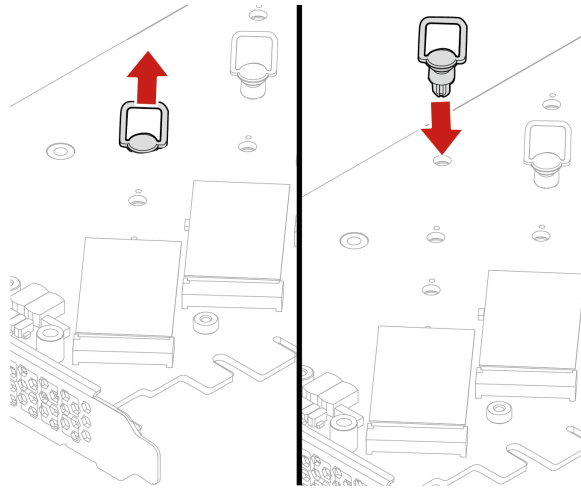

7. If necessary, remove the film on the thermal pad on which you want to install the M.2 solid-state drive. Pull the handle of the retention latch outward to the open position.

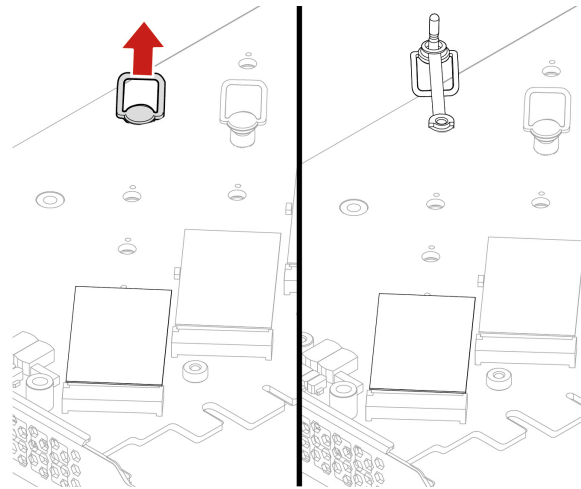

8. Install the M.2 solid-state drive. Then, insert the plug of the retention latch into the hole to secure the new drive.

Note: Do not touch the circuit board of the M.2 solid-state drive.

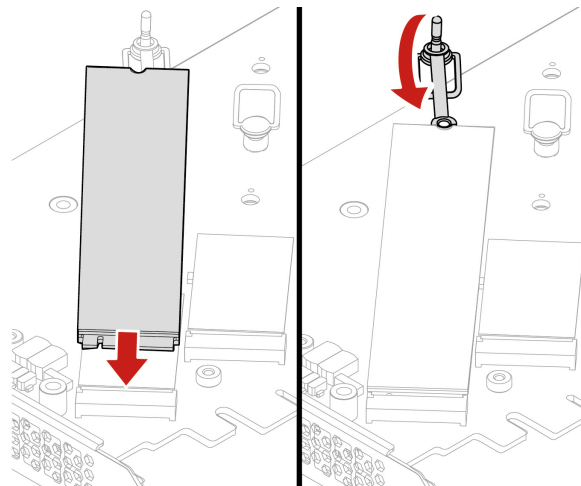

9. Install the heat sink for the M.2 solid-state drive.

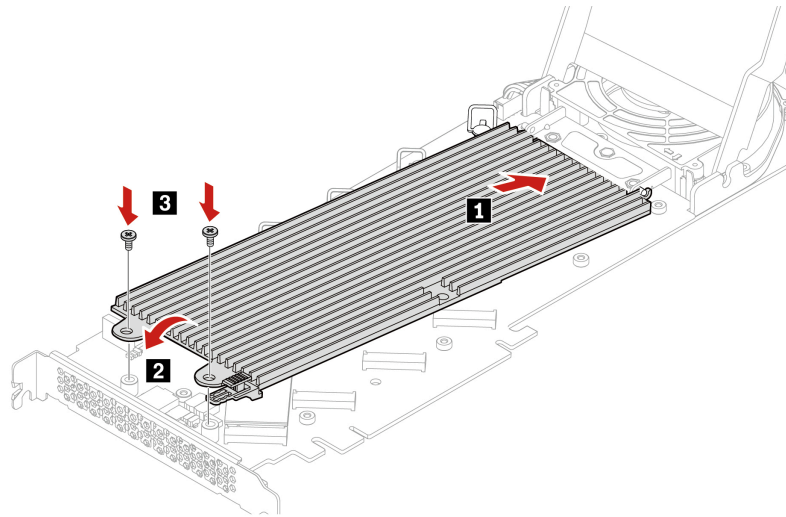

10. Close the cover.

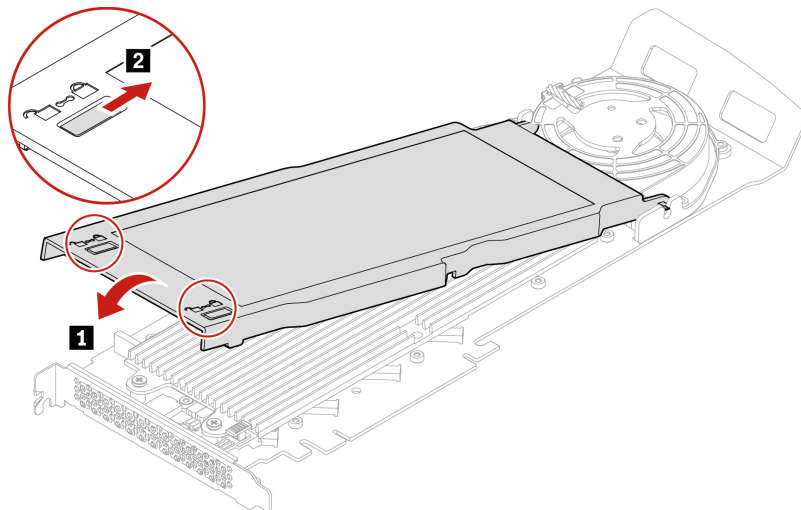

11. Install the M.2 solid-state drive PCIe adapter in a PCIe x16 card slot on the system board. See “System board illustration” on page 4.

12. Reinstall all removed parts. Then, reconnect the power cord and all disconnected cables to the computer.

- Type 2

Install M.2 solid-state drives in the following order.

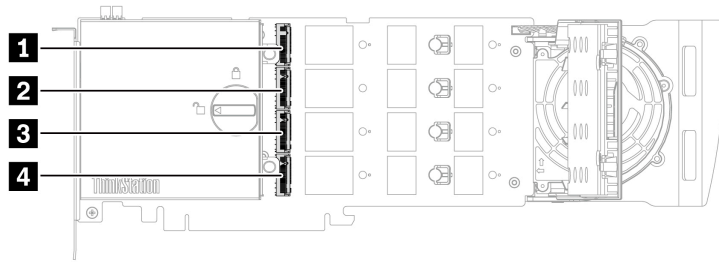

1. Remove the computer cover. See “Computer cover” on page 39.
2. Remove the M.2 solid-state drive PCIe adapter from the PCIe card slot. See “Full-length PCIe card” on page 80.
3. Open the cover.

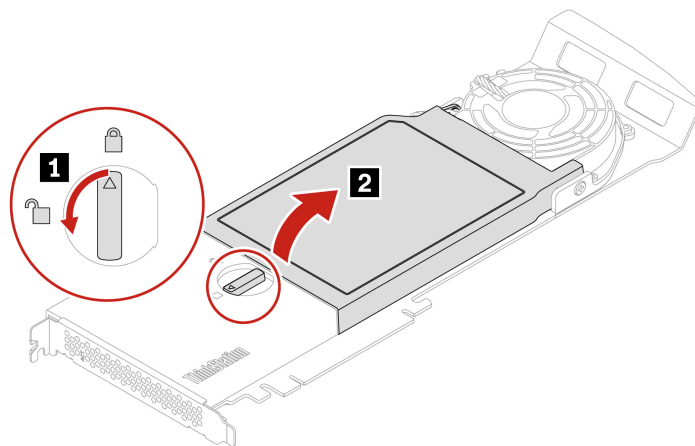

4. Pull the handle of the retention latch outward to release the M.2 solid-state drive. Then, remove the M.2 solid-state drive from the PCIe adapter.

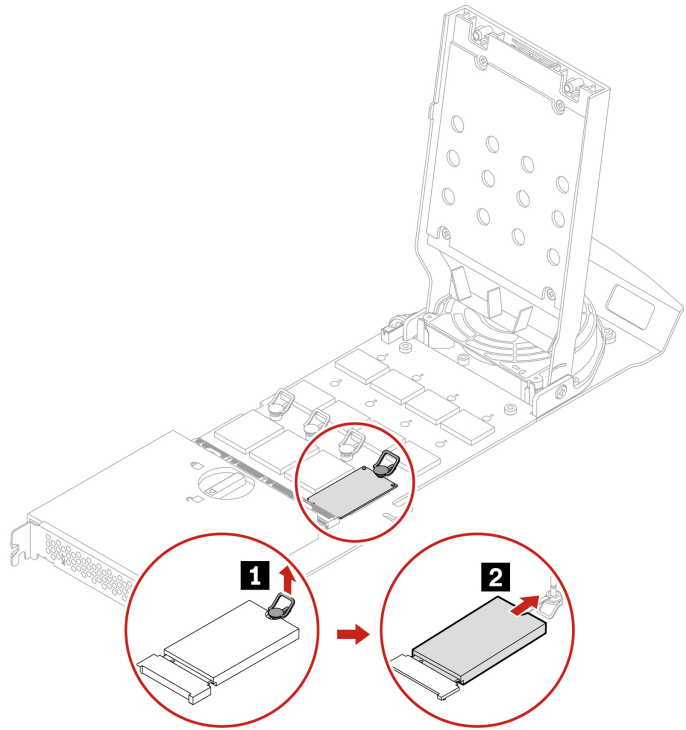

5. If necessary, move the retention latch to an appropriate location to suit the length of the new M.2 solid-state drive.

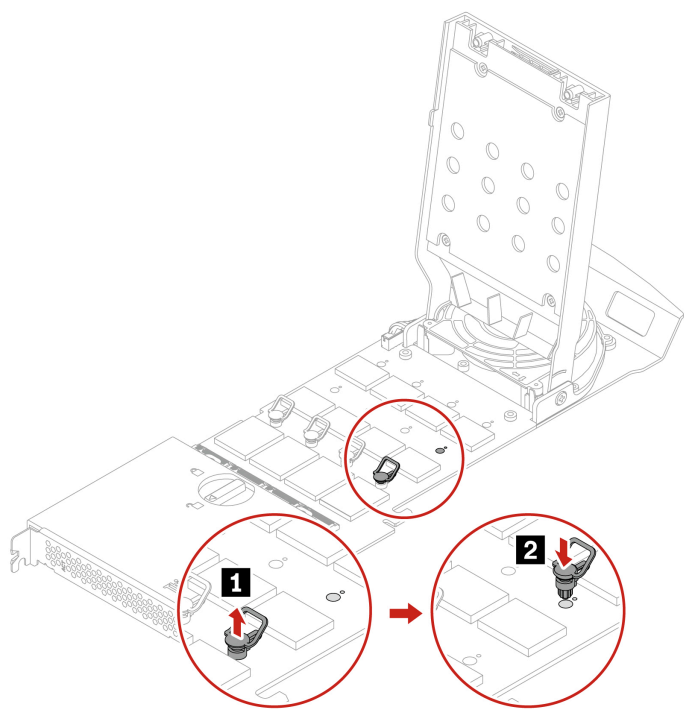

6. If necessary, remove the film on the thermal pad on which you want to install the M.2 solid-state drive. Pull the handle of the retention latch outward to the open position.

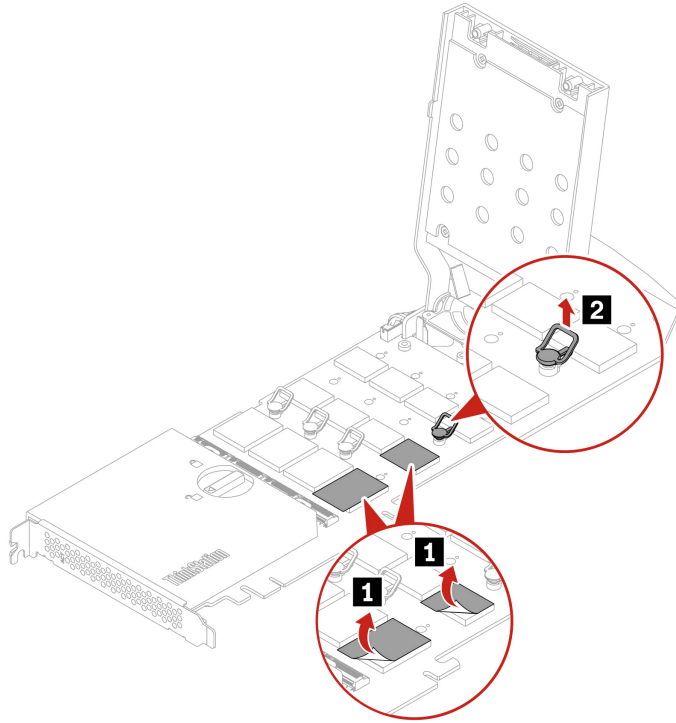

7. Install the M.2 solid-state drive. Then, insert the plug of the retention latch into the hole to secure the new drive.

Note: Do not touch the circuit board of the M.2 solid-state drive.

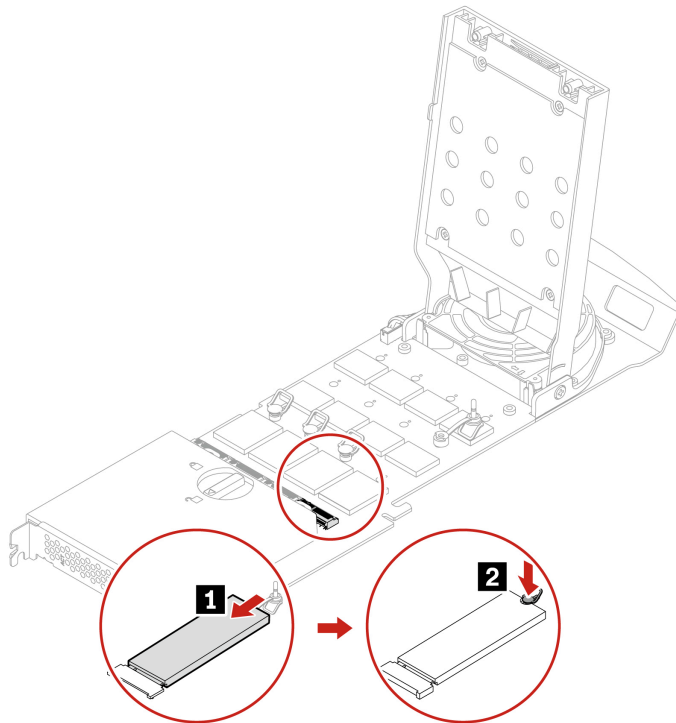

8. Close the cover.

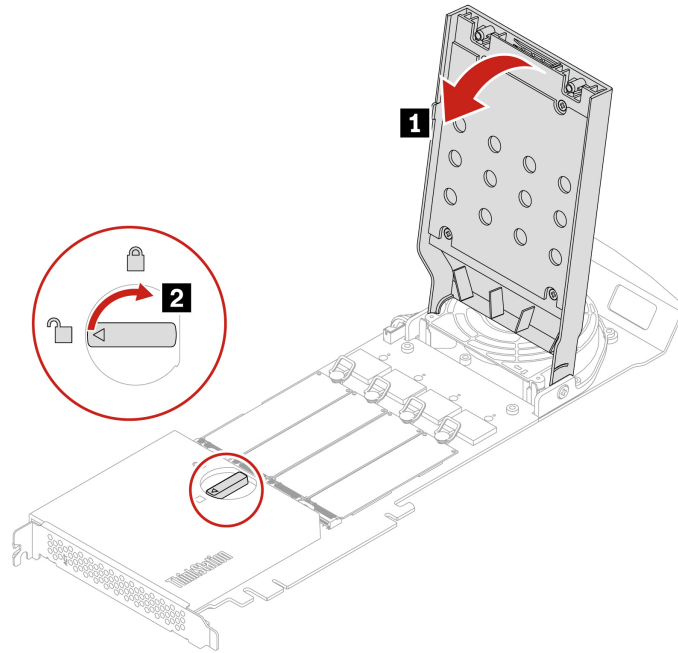

9. Install the M.2 solid-state drive PCIe adapter in a PCIe x16 card slot on the system board. See “System board illustration” on page 4.
10. Reinstall all removed parts. Then, reconnect the power cord and all disconnected cables to the computer.

U.2 or U.3 solid-state drive in an U.2 or U.3 solid-state drive PCIe adapter

Prerequisite

Before you start, read *Generic Safety and Compliance Notices*, and print the following instructions.

Attention: The internal storage drive is sensitive. Inappropriate handling might cause damage and permanent loss of data. When handling the internal storage drive, observe the following guidelines:

- Replace the internal storage drive only for upgrade or repair. The internal storage drive is not designed for frequent changes or replacement.
- Before replacing the internal storage drive, make a backup copy of all the data that you want to keep.
- Do not touch the contact edge of the internal storage drive. Otherwise, the internal storage drive might get damaged.
- Do not apply pressure to the internal storage drive.
- Do not make the internal storage drive subject to physical shocks or vibration. Put the internal storage drive on a soft material, such as cloth, to absorb physical shocks.

Replacement procedure

1. Remove the computer cover. See “Computer cover” on page 39.
2. Remove the U.2 or U.3 solid-state drive PCIe adapter from the PCIe card slot. See “Full-length PCIe card” on page 80.
3. Open the cover.

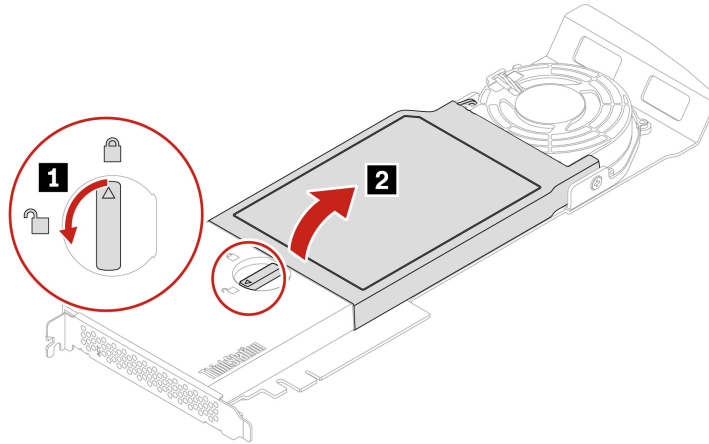

4. Remove the SSD.

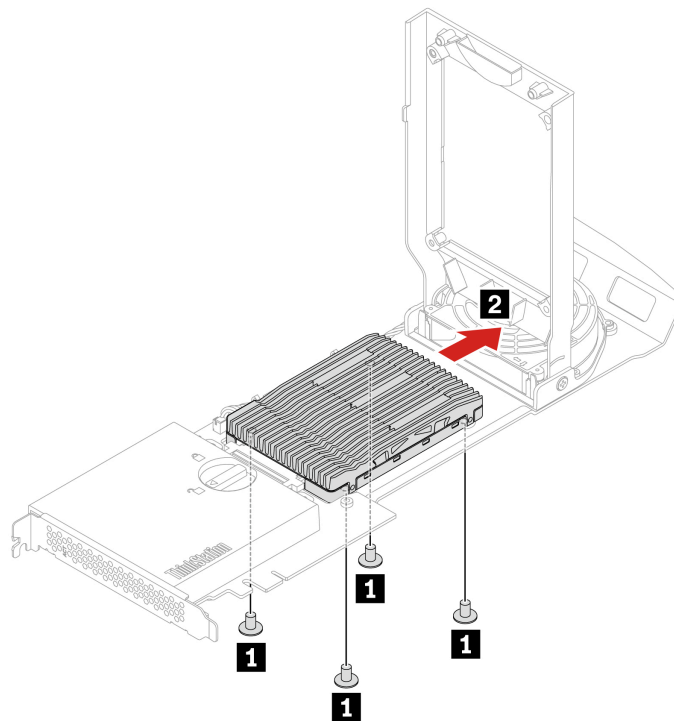

5. Install the U.2 or U.3 solid-state drive.

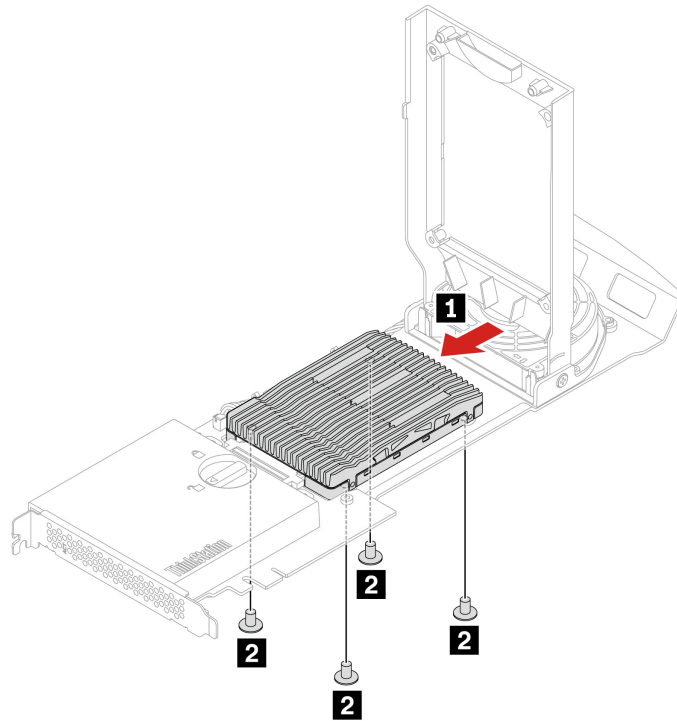

6. Close the cover.

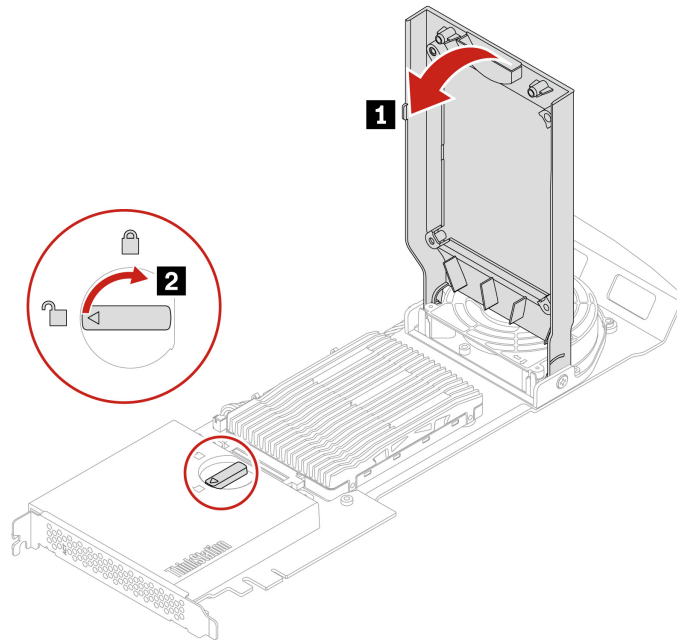

7. Install the U.2 or U.3 solid-state drive PCIe adapter in a PCIe x16 card slot on the system board. See “System board illustration” on page 4.
8. Reinstall all removed parts. Then, reconnect the power cord and all disconnected cables to the computer.

Power supply assembly

Prerequisite

Before you start, read *Generic Safety and Compliance Notices*, and print the following instructions.

Although there are no moving parts in the computer after the power cord has been disconnected, the following warnings are required for your safety.



Keep fingers and other parts of your body away from hazardous, moving parts. If you suffer an injury, seek medical care immediately. Never remove the cover on a power supply or any part that has the following label attached.



Hazardous voltage, current, and energy levels are present inside any component that has this label attached. There are no serviceable parts inside these components. If you suspect a problem with one of these parts, contact a service technician.

Replacement procedure

1. Remove the computer cover. See “Computer cover” on page 39.
2. Remove the power supply assembly.

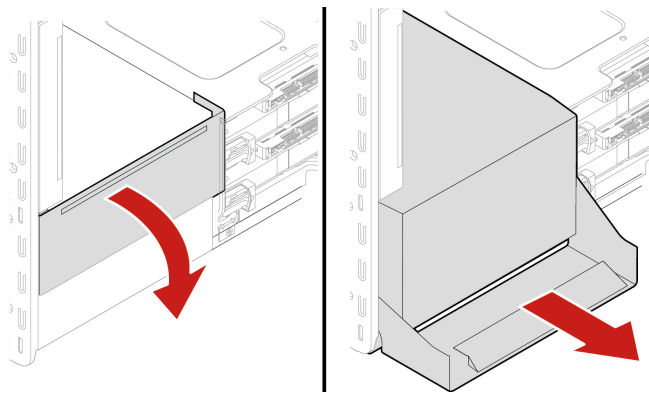

3. Install the power supply assembly.

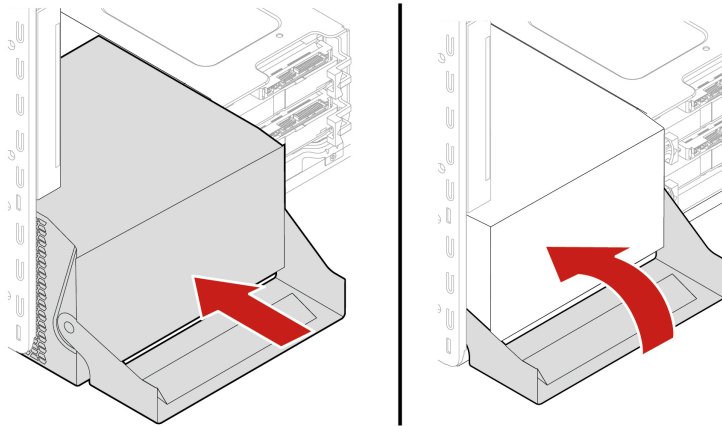

4. Reinstall all removed parts. Then, reconnect the power cord and all disconnected cables to the computer.

PCIe card

Prerequisite

Before you start, read *Generic Safety and Compliance Notices*, and print the following instructions.

Install PCIe cards according to the corresponding slot types and the following illustrated installation order:

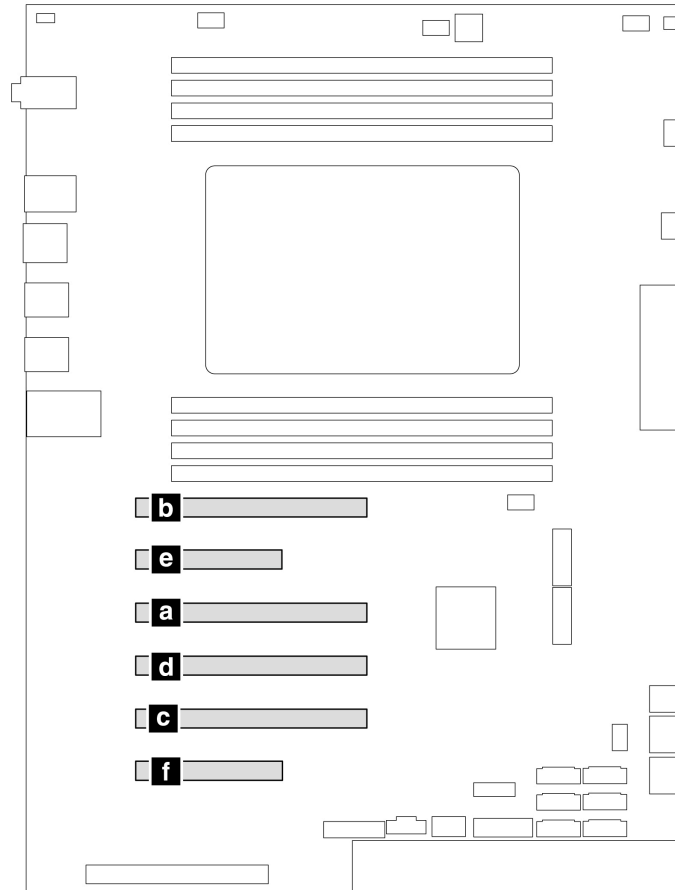
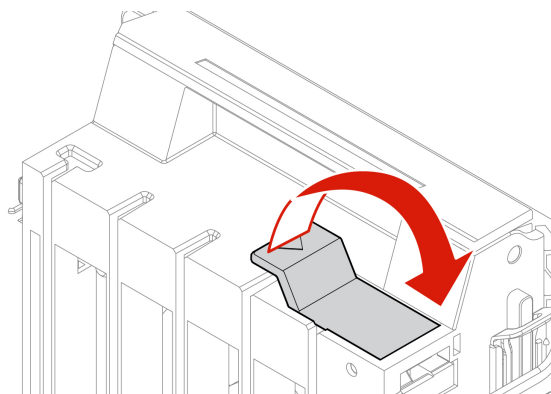

Figure 2. PCIe card installation order

Replacement procedure

1. Remove the computer cover. See “Computer cover” on page 39.
2. Lay the computer on its side for easier access to the system board.
3. Open the latch in the front fan assembly and remove the PCIe card retainer.

Note: The PCIe card retainer is only available on some models.



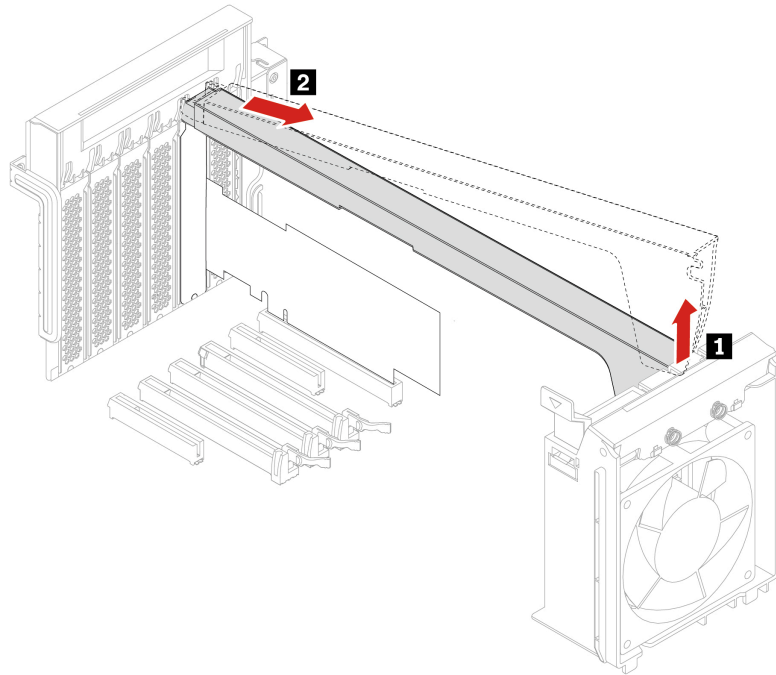

4. Remove the PCIe card.

Note: The card might fit tightly into the slot. If necessary, alternately move each side of the card a small amount until the card is removed from the slot.

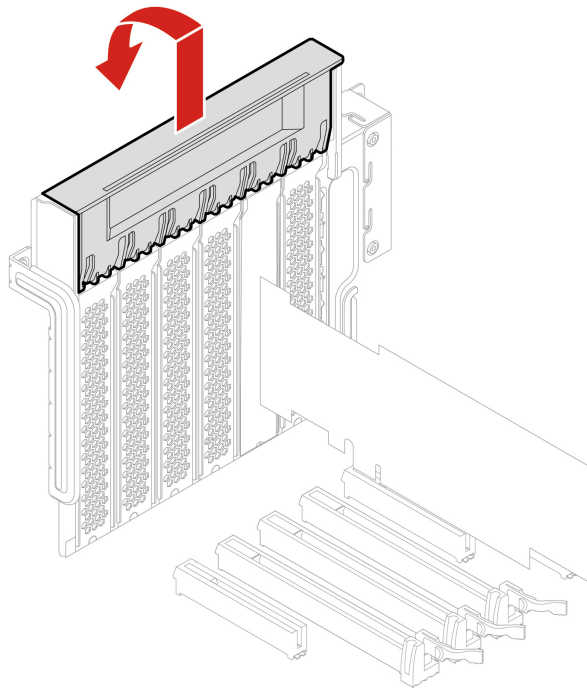

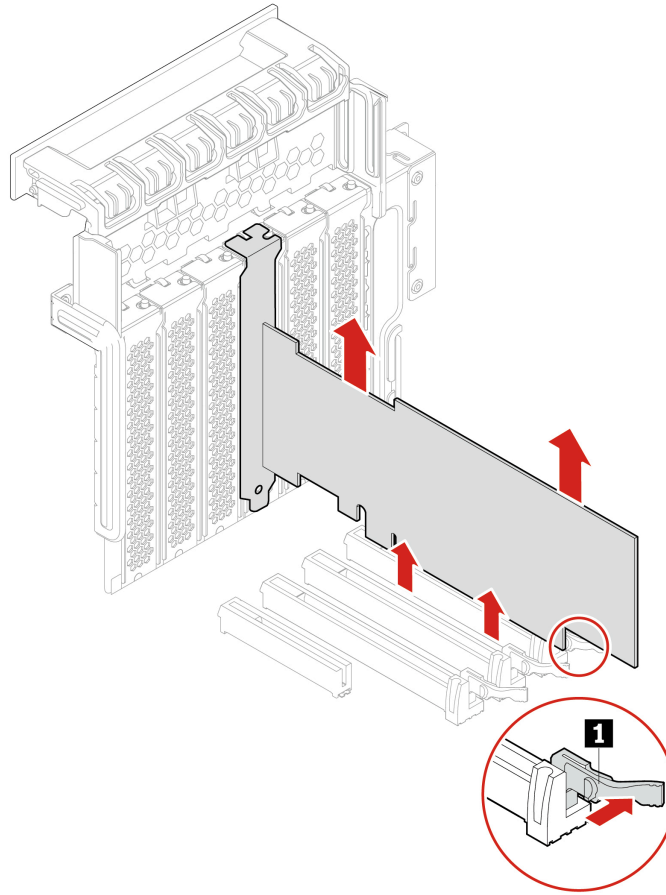

5. To install a new PCIe card, pivot the PCIe card latch to the open position.
6. Remove the appropriate metal slot cover. Install the new card into the appropriate slot on the system board. See “System board illustration” on page 4.
7. Pivot the PCIe card latch and push it back in until it snaps into position.
8. Install a PCIe card retainer, if any.

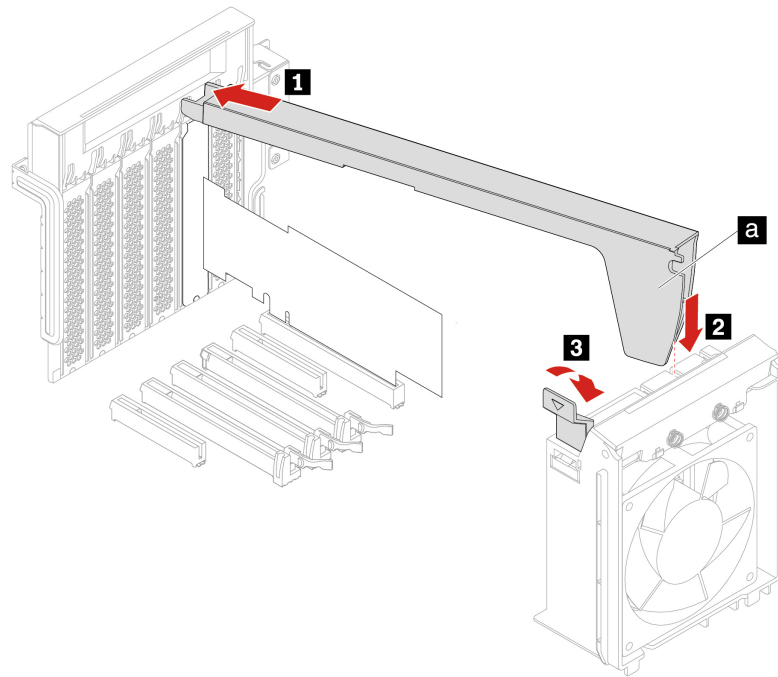

Full-length PCIe card

Prerequisite

Before you start, read *Generic Safety and Compliance Notices*, and print the following instructions.

Install PCIe cards (except GeforceRTX 40xx) according to the corresponding slot types and the following illustrated installation order:

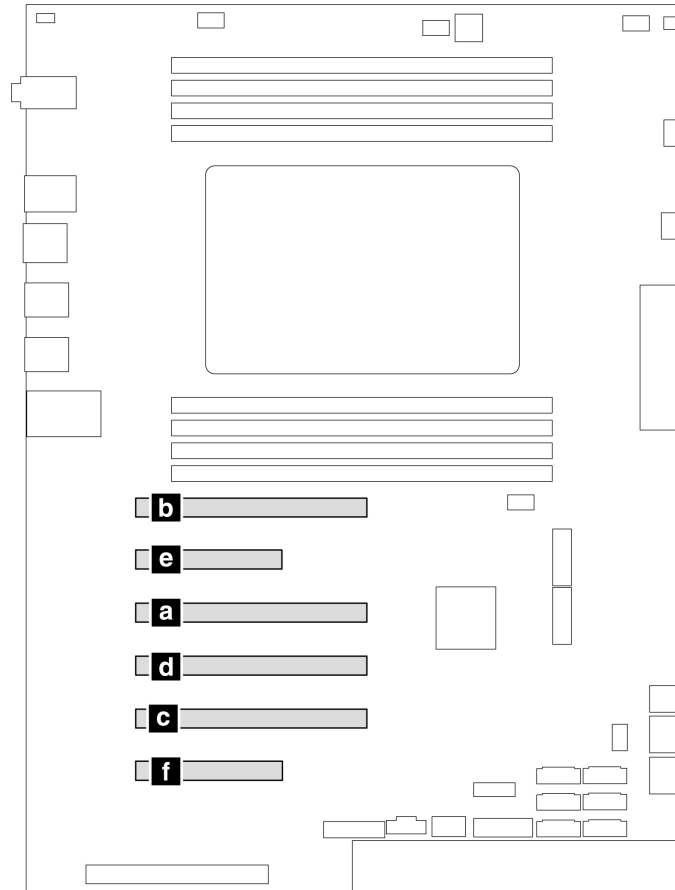

Figure 3. PCIe cards (except GeforceRTX 40xx) installation order

Install the graphics card GeforceRTX 40xx according to the corresponding slot types and the following illustrated installation order:

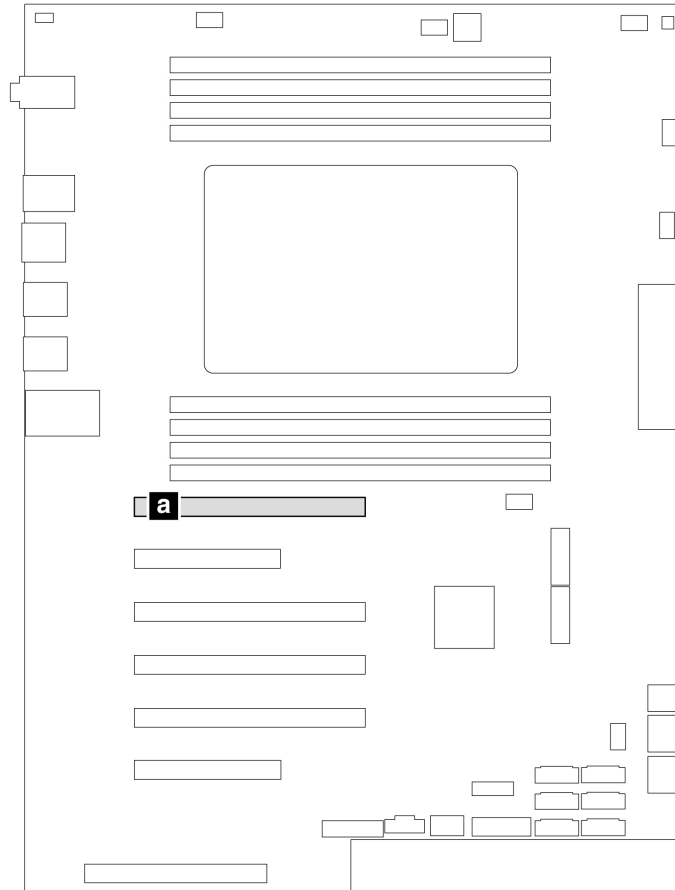
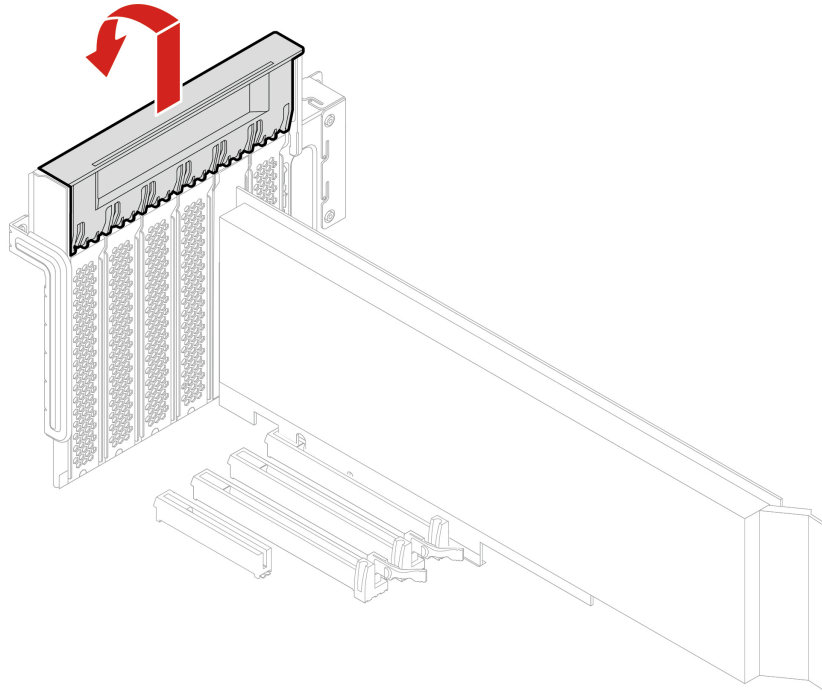

Figure 4. GeForce RTX 40xx installation order

Replacement procedure

1. Remove the computer cover. See “Computer cover” on page 39.
2. Lay the computer on its side for easier access to the system board.
3. Open the PCIe card latch.



4. Open the latch in the front fan assembly.

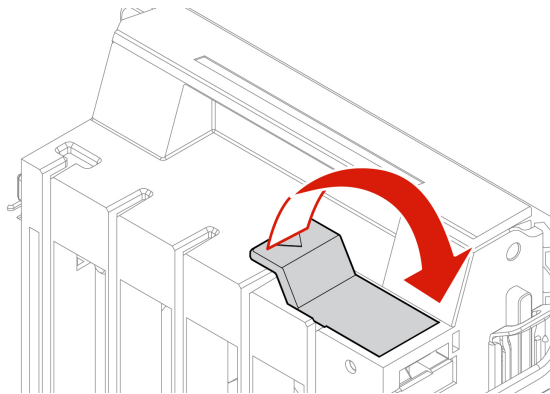

5. Disconnect the power cable from the full-length PCIe card. Then, remove the card.

Note: The card might fit tightly into the slot. If necessary, alternately move each side of the card a small amount until the card is removed from the slot.

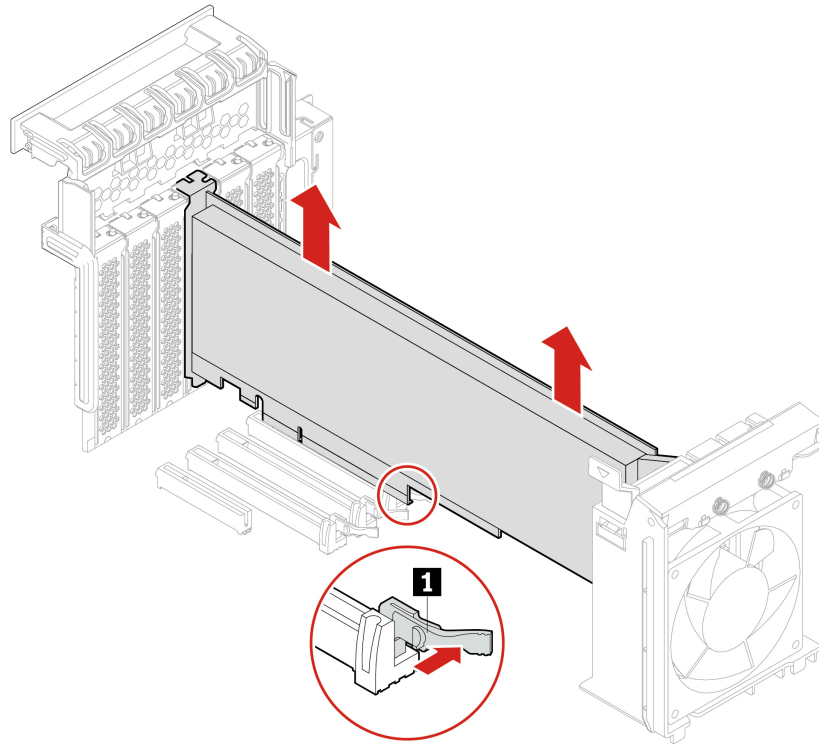

6. To install a full-length PCIe card:

- a. If you are installing a new full-length PCIe card, open PCIe card latch and remove the appropriate metal slot cover.
- b. Align the extender on the new full-length PCIe card with the corresponding slot in the front fan assembly. Then, install the new card into the appropriate slot on the system board. See “System board illustration” on page 4.

Note: It is recommended that you install the full-length PCIe card into a PCIe x16 card slot for best performance.

7. Pivot the PCIe card latch and push it back in until it snaps into position. Then, pivot the tab on the front fan assembly to close the latch inside.
8. Connect one end of the power cable to the new full-length PCIe card and the other end to the appropriate power connector on the system board. See “System board illustration” on page 4.
9. Reinstall all removed parts. Then, reconnect the power cord and all disconnected cables to the computer.

Super capacitor module

Prerequisite

Before you start, read *Generic Safety and Compliance Notices*, and print the following instructions.

For access, do the following:

1. Remove the computer cover. See “Computer cover” on page 39.
2. Lay the computer on its side for easier access to the system board.

Removal steps

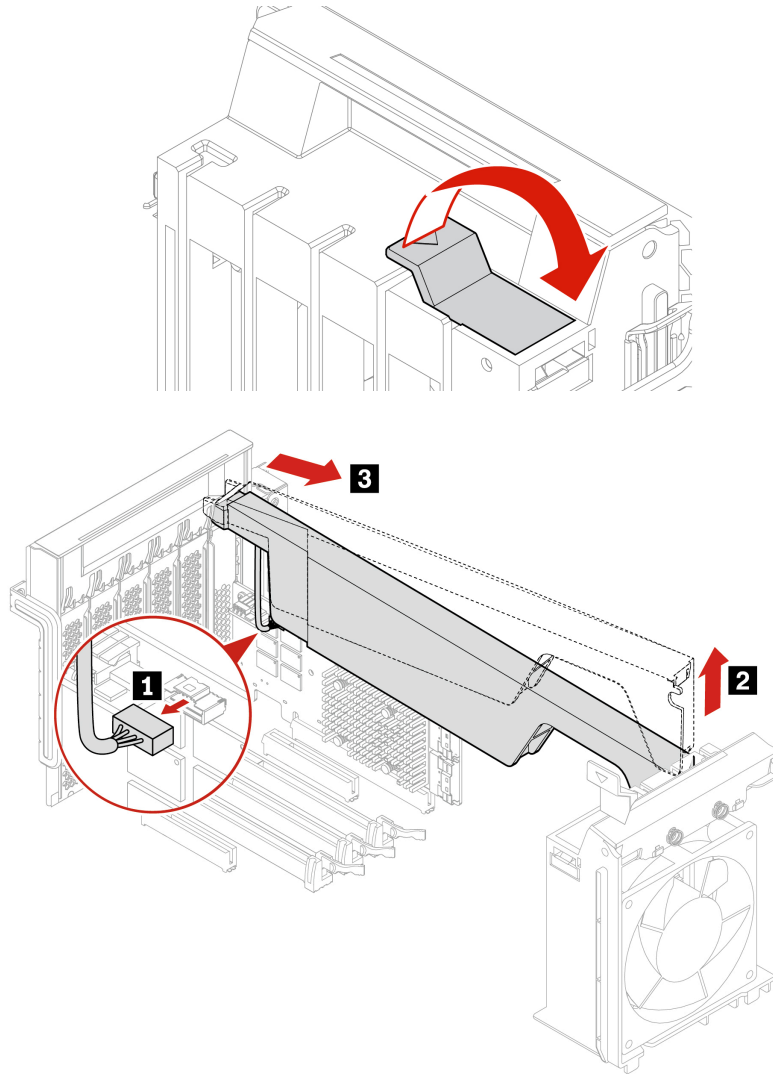

Note: When installing a new super capacitor module, connect the super capacitor module cable to the super capacitor module connector (J14) on the RAID card.

Front fan assembly

Prerequisite

Before you start, read *Generic Safety and Compliance Notices*, and print the following instructions.

CAUTION:



Keep fingers and other parts of your body away from hazardous, moving parts. If you suffer an injury, seek medical care immediately.

Replacement procedure

1. Remove the computer cover. See “Computer cover” on page 39.
2. Remove the following devices if any:

- Full-length PCIe cards, see “Full-length PCIe card” on page 80
 - PCIe card retainer, see “PCIe card” on page 76
3. Remove the front fan assembly.

Note: When you slide out the front fan assembly, avoid pulling the front-fan-assembly cable.

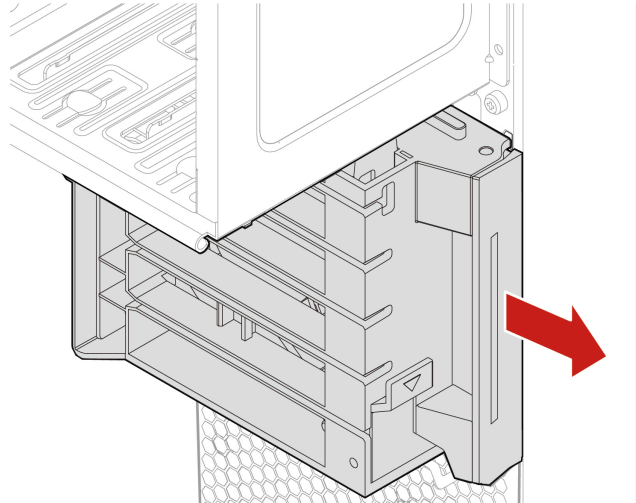

4. Disconnect the front-fan-assembly cable from the front-fan-assembly connector on the system board.
5. Connect the cable of the new front fan assembly to the front-fan-assembly connector on the system board. See “System board illustration” on page 4.
6. Install a new front fan assembly.

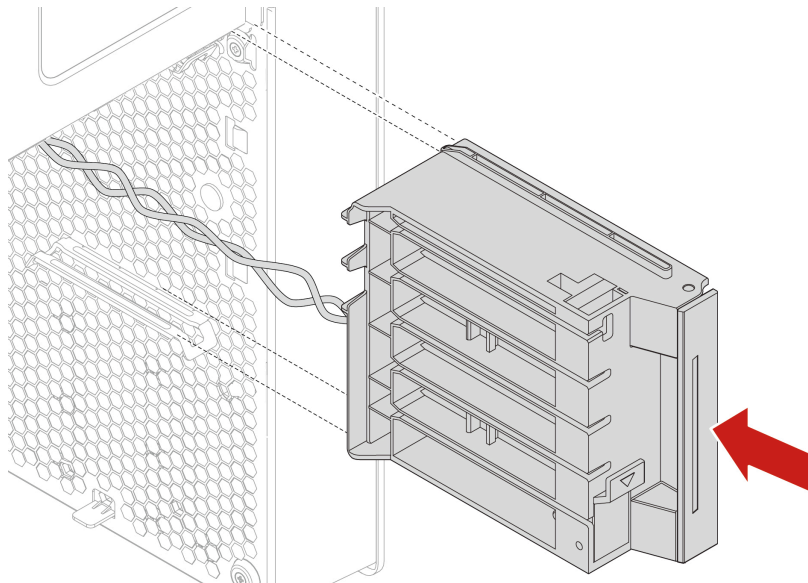

7. Reinstall all removed parts. Then, reconnect the power cord and all disconnected cables to the computer.

Rear fan assembly

Prerequisite

Before you start, read *Generic Safety and Compliance Notices*, and print the following instructions.

CAUTION:



Keep fingers and other parts of your body away from hazardous, moving parts. If you suffer an injury, seek medical care immediately.

Replacement procedure

1. Remove the computer cover. See “Computer cover” on page 39.
2. Disconnect the rear-fan-assembly cable from the rear-fan-assembly connector on the system board.
3. Remove the rear fan assembly.

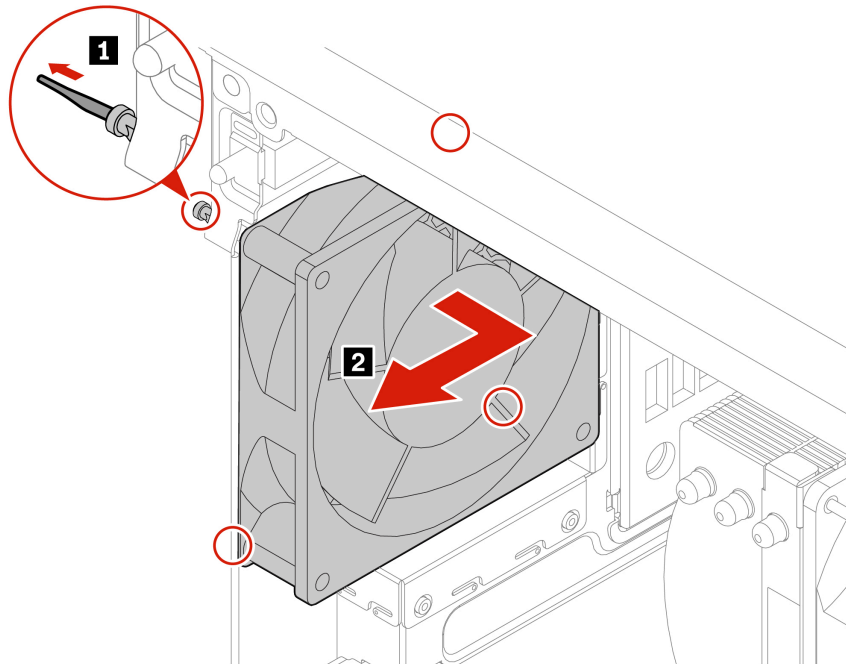

4. Install a new rear fan assembly.

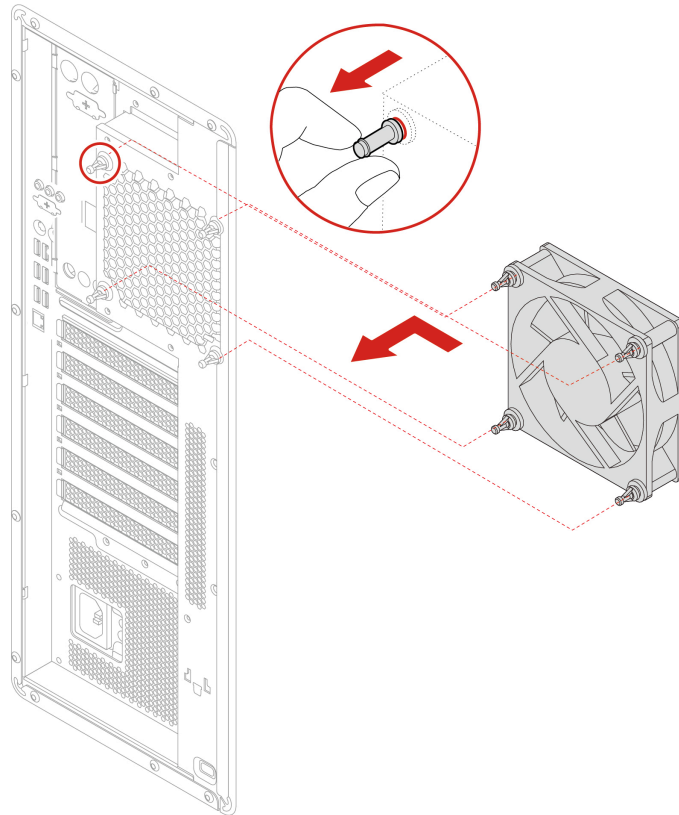

5. Connect the rear-fan-assembly cable to the rear-fan-assembly connector on the system board. See “System board illustration” on page 4.
6. Reinstall all removed parts. Then, reconnect the power cord and all disconnected cables to the computer.

Memory module active cooler and duct

Prerequisite

Before you start, read *Generic Safety and Compliance Notices*, and print the following instructions.

Replacement procedure

1. Remove the computer cover. See “Computer cover” on page 39.
2. Lay the computer on its side for easier access to the system board.
3. Remove the memory module active cooler and duct.

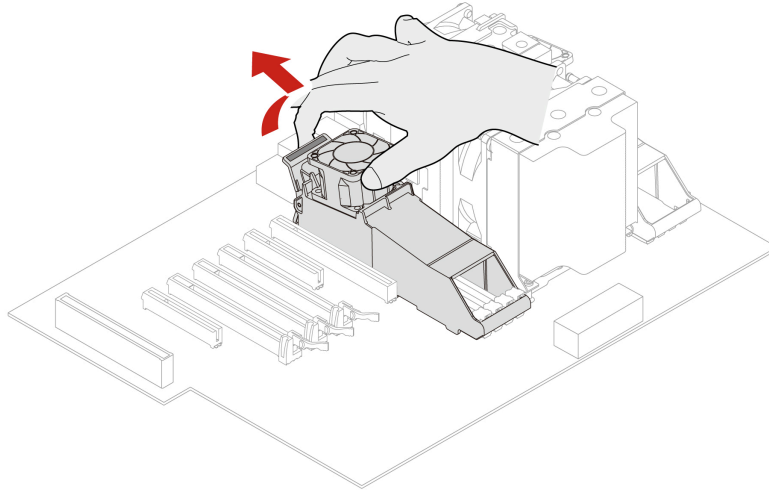

4. Install a memory module active cooler and duct.

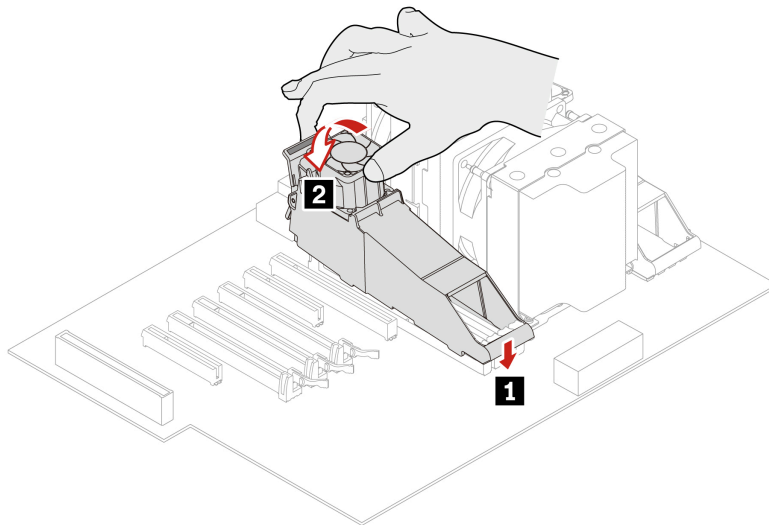

5. Reinstall all removed parts. Then, reconnect the power cord and all disconnected cables to the computer.

Memory module

Prerequisite

Before you start, read *Generic Safety and Compliance Notices*, and print the following instructions.

Your computer has eight slots for installing DDR4 RDIMMs that provide up to a maximum of 512 GB system memory. When removing or installing a memory module, use the following guidelines:

- Use 16 GB, 32 GB, or 64 GB DDR4 ECC RDIMMs in any combination up to a maximum of 512 GB.
- Ensure that you follow the installation order for memory modules shown in the following table.

Memory modules	Installation order
one	Slot 7
two	Slot 7 and slot 8
Four	Slot 7, slot 8, slot 2, and slot 1
Eight	Slot 1 to slot 8

Replacement procedure

1. Remove the computer cover. See “Computer cover” on page 39.
2. Lay the computer on its side for easier access to the system board.
3. Remove the memory cooler and duct. See “Memory module active cooler and duct” on page 88.
4. Remove the memory module.

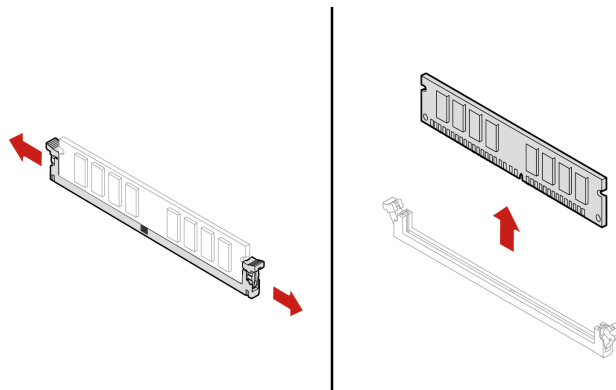

5. Install a memory module.

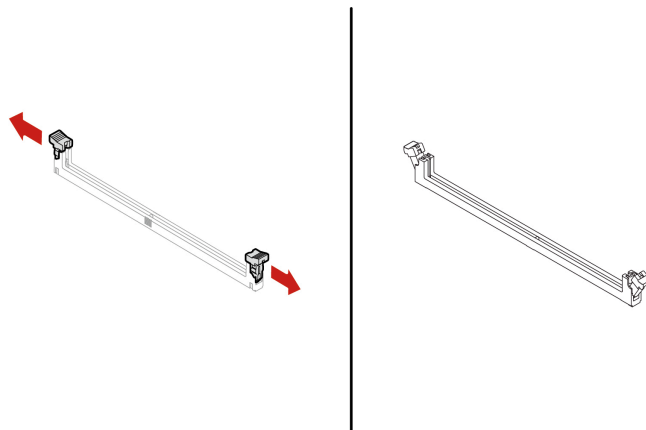

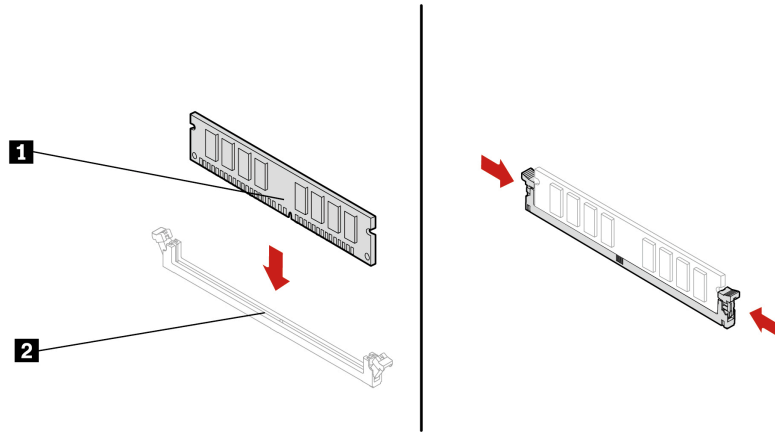

6. Reinstall all removed parts. Then, reconnect the power cord and all disconnected cables to the computer.

Chapter 9. Help and support

Self-help resources

Use the following self-help resources to learn more about the computer and troubleshoot problems.

Resources	How to access?
Troubleshooting and frequently asked questions	<ul style="list-style-type: none">• https://www.lenovo.com/tips• https://forums.lenovo.com
Accessibility information	https://www.lenovo.com/accessibility
Reset or restore Windows	<ul style="list-style-type: none">• Use Lenovo recovery options.<ol style="list-style-type: none">1. Go to https://support.lenovo.com/HowToCreateLenovoRecovery.2. Follow the on-screen instructions.• Use Windows recovery options.<ol style="list-style-type: none">1. Go to https://pcsupport.lenovo.com.2. Detect your computer or manually select your computer model.3. Navigate to the troubleshooting menu to diagnose the operating system for recovery instructions.
Use the Vantage app to:	
<ul style="list-style-type: none">• Configure device settings.• Download and install UEFI BIOS, drivers and firmware updates.• Secure your computer from outside threats.• Diagnose hardware problems.• Check the computer warranty status.• Access <i>User Guide</i> and helpful articles.	Type Vantage in the Windows search box.
Note: The available features vary depending on the computer model.	
Product documentation:	
<ul style="list-style-type: none">• <i>Safety and Warranty Guide</i>• <i>Generic Safety and Compliance Notices</i>• <i>Setup Guide</i>• <i>This User Guide</i>• <i>Regulatory Notice</i>	Go to https://pcsupport.lenovo.com . Then, follow the on-screen instructions to filter out the documentation you want.

Resources	How to access?
Lenovo Support Web site with the latest support information of the following:	https://pcsupport.lenovo.com
<ul style="list-style-type: none"> • Drivers and software • Diagnostic solutions • Product and service warranty • Product and parts details • Knowledge base and frequently asked questions 	
Windows help information	<ul style="list-style-type: none"> • Type Get Help or Tips in the Windows search box and then press Enter. • Use Windows Search or the Cortana® personal assistant. • Microsoft support Web site: https://support.microsoft.com

Call Lenovo

If you have tried to correct the problem yourself and still need help, you can call Lenovo Customer Support Center.

Before you contact Lenovo

Prepare the following before you contact Lenovo:

1. Record the problem symptoms and details:
 - What is the problem? Is it continuous or intermittent?
 - Any error message or error code?
 - What operating system are you using? Which version?
 - Which software applications were running at the time of the problem?
 - Can the problem be reproduced? If so, how?
2. Record the system information:
 - Product name
 - Machine type and serial number

The following illustration shows where to find the machine type and serial number of your computer.

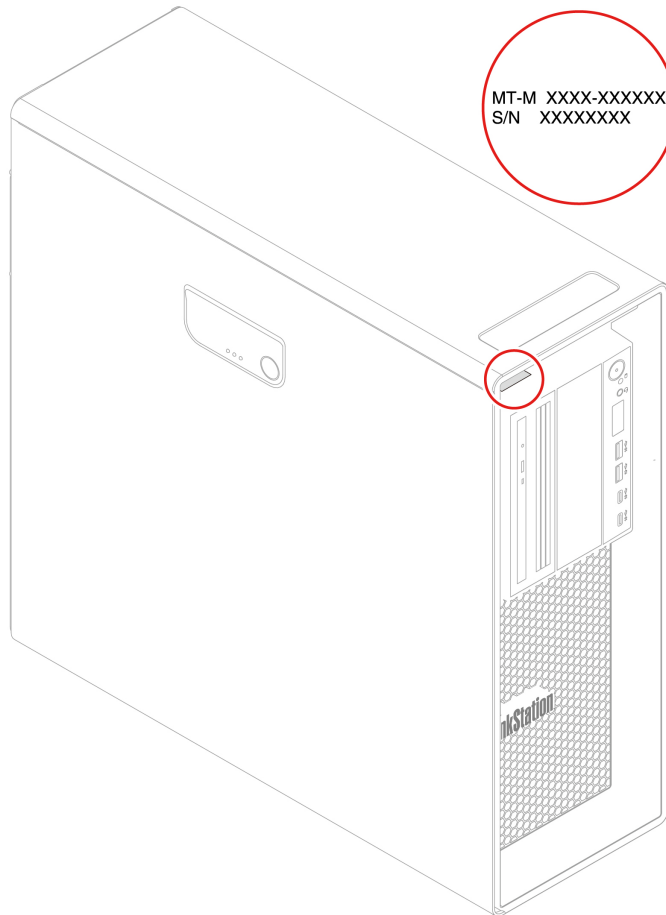

Lenovo Customer Support Center

During the warranty period, you can call Lenovo Customer Support Center for help.

Telephone numbers

For a list of the Lenovo Support phone numbers for your country or region, go to:

<https://pcsupport.lenovo.com/supportphonenumberlist>

Note: Phone numbers are subject to change without notice. If the number for your country or region is not provided, contact your Lenovo reseller or Lenovo marketing representative.

Services available during the warranty period

- Problem determination - Trained personnel are available to assist you with determining if you have a hardware problem and deciding what action is necessary to fix the problem.
- Lenovo hardware repair - If the problem is determined to be caused by Lenovo hardware under warranty, trained service personnel are available to provide the applicable level of service.
- Engineering change management - Occasionally, there might be changes that are required after a product has been sold. Lenovo or your reseller, if authorized by Lenovo, will make selected Engineering Changes (ECs) that apply to your hardware available.

Services not covered

- Replacement or use of parts not manufactured for or by Lenovo or nonwarranted parts

- Identification of software problem sources
- Configuration of UEFI BIOS as part of an installation or upgrade
- Changes, modifications, or upgrades to device drivers
- Installation and maintenance of network operating systems (NOS)
- Installation and maintenance of programs

For the terms and conditions of the Lenovo Limited Warranty that apply to your Lenovo hardware product, see *Safety and Warranty Guide* that comes with your computer.

Certification-related information

Product name: ThinkStation P620

Machine types: 30E0 and 30E1

Compliance information

For more compliance information, refer to *Regulatory Notice* at https://support.lenovo.com/docs/common_commercial_rn and *Generic Safety and Compliance Notices* at https://pcsupport.lenovo.com/docs/generic_notices.

Purchase additional services

During and after the warranty period, you can purchase additional services from Lenovo at: <https://pcsupport.lenovo.com/warrantyupgrade>

Service availability and service name might vary by country or region.

Accessibility features

Lenovo is committed to making information technology accessible to everyone, including individuals with hearing, vision, mobility, cognitive, or speech disabilities. To get the most up-to-date and detailed accessibility features information for the product, go to https://support.lenovo.com/docs/product_accessibility_features.

Appendix A. Supplemental information about the Ubuntu operating system

In limited countries or regions, Lenovo offers customers an option to order computers with the preinstalled Ubuntu® operating system.

If the Ubuntu operating system is available on your computer, read the following information before you use the computer. Ignore any information related to Windows-based programs, utilities, and Lenovo preinstalled applications in this documentation.

Access the Lenovo Limited Warranty

This product is covered by the terms of the Lenovo Limited Warranty (LLW), version L505-0010-02 08/2011. You can view the LLW in a number of languages from the following Web site. Read the Lenovo Limited Warranty at:

https://www.lenovo.com/warranty/llw_02

The LLW also is preinstalled on the computer. To access the LLW, go to the following directory:

```
/opt/Lenovo
```

If you cannot view the LLW either from the Web site or from your computer, contact your local Lenovo office or reseller to obtain a printed version of the LLW.

Access the Ubuntu help system

The Ubuntu help system provides information about how to use the Ubuntu operating system. To access the help system from Home Screen, move your pointer to the Launch bar, and then click the **Help** icon. If you cannot find the **Help** icon from the Launch bar, click the **Search** icon on the bottom left, and type Help to search it.

To learn more about the Ubuntu operating system, go to:

<https://www.ubuntu.com>

Get support information

If you need help, service, technical assistance, or more information about the Ubuntu operating system or other applications, contact the provider of the Ubuntu operating system or the provider of the application. If you need the service and support for hardware components shipped with your computer, contact Lenovo. For more information about how to contact Lenovo, refer to the *User Guide* and *Safety and Warranty Guide*.

To access the latest *User Guide* and *Safety and Warranty Guide*, go to:

<https://pcsupport.lenovo.com>

Appendix B. Notices and trademarks

Notices

Lenovo may not offer the products, services, or features discussed in this document in all countries. Consult your local Lenovo representative for information on the products and services currently available in your area. Any reference to a Lenovo product, program, or service is not intended to state or imply that only that Lenovo product, program, or service may be used. Any functionally equivalent product, program, or service that does not infringe any Lenovo intellectual property right may be used instead. However, it is the user's responsibility to evaluate and verify the operation of any other product, program, or service.

Lenovo may have patents or pending patent programs covering subject matter described in this document. The furnishing of this document does not give you any license to these patents. You can send license inquiries, in writing, to:

*Lenovo (United States), Inc.
8001 Development Drive
Morrisville, NC 27560
U.S.A.
Attention: Lenovo Director of Licensing*

LENOVO PROVIDES THIS PUBLICATION "AS IS" WITHOUT WARRANTY OF ANY KIND, EITHER EXPRESS OR IMPLIED, INCLUDING, BUT NOT LIMITED TO, THE IMPLIED WARRANTIES OF NON-INFRINGEMENT, MERCHANTABILITY OR FITNESS FOR A PARTICULAR PURPOSE. Some jurisdictions do not allow disclaimer of express or implied warranties in certain transactions, therefore, this statement may not apply to you.

Changes are made periodically to the information herein; these changes will be incorporated in new editions of the publication. To provide better service, Lenovo reserves the right to improve and/or modify the products and software programs described in the manuals included with your computer, and the content of the manual, at any time without additional notice.

The software interface and function and hardware configuration described in the manuals included with your computer might not match exactly the actual configuration of the computer that you purchase. For the configuration of the product, refer to the related contract (if any) or product packing list, or consult the distributor for the product sales. Lenovo may use or distribute any of the information you supply in any way it believes appropriate without incurring any obligation to you.

The products described in this document are not intended for use in implantation or other life support applications where malfunction may result in injury or death to persons. The information contained in this document does not affect or change Lenovo product specifications or warranties. Nothing in this document shall operate as an express or implied license or indemnity under the intellectual property rights of Lenovo or third parties. All information contained in this document was obtained in specific environments and is presented as an illustration. The result obtained in other operating environments may vary.

Lenovo may use or distribute any of the information you supply in any way it believes appropriate without incurring any obligation to you.

Any references in this publication to non-Lenovo Web sites are provided for convenience only and do not in any manner serve as an endorsement of those Web sites. The materials at those Web sites are not part of the materials for this Lenovo product, and use of those Web sites is at your own risk.

Any performance data contained herein was determined in a controlled environment. Therefore, the result obtained in other operating environments may vary significantly. Some measurements may have been made on development-level systems and there is no guarantee that these measurements will be the same on generally available systems. Furthermore, some measurements may have been estimated through extrapolation. Actual results may vary. Users of this document should verify the applicable data for their specific environment.

This document is copyrighted by Lenovo and is not covered by any open source license, including any Linux agreement(s) which may accompany software included with this product. Lenovo may update this document at any time without notice.

For the latest information or any questions or comments, contact or visit the Lenovo Web site:
<https://pcsupport.lenovo.com>

Trademarks

LENOVO, LENOVO logo, THINKSTATION, and THINKSTATION logo are trademarks of Lenovo. Microsoft, Windows, Direct3D, and Cortana are trademarks of the Microsoft group of companies. Wi-Fi and Miracast are registered trademarks of Wi-Fi Alliance. Linux is a registered trademark of Linus Torvalds. Ubuntu is a registered trademark of Canonical Ltd. USB-C is a registered trademark of USB Implementers Forum. All other trademarks are the property of their respective owners.

Lenovo